

Energy-Efficient Power Management for Coordinated Relays and User Equipment in LTE-TDD Networks

Ming-Hua Huang, Kuo-Feng Lee, Yu-Hsin Liao, and Chia-Hao Lo

Department of Electrical Engineering, National Chiao Tung University, Hsinchu, Taiwan; Institute of Information and Communication Engineering, National Tsing Hua University, Hsinchu, Taiwan

Abstract—In this paper, the design of integrated sleep scheduling for relay nodes and user equipments under a Donor eNB (DeNB) in the mode of Time Division Duplex (TDD) in LTE-A is presented. The idea of virtual time is proposed to deal with the discontinuous pattern of the available radio resource in TDD, and based on the estimation of the traffic load, three power saving schemes in the top-down strategy are presented. Associated mechanisms in each scheme including calculation of the virtual subframe capacity, the algorithm of integrated sleep scheduling, and the mapping mechanisms for the backhaul link and the access link are presented in the paper. Simulation study shows the advantage of the proposed schemes in energy saving over the standard DRX scheme.

I. INTRODUCTION

D

EPLOYMENT of LTE network [1] has been rapidly advancing worldwide in recent years. Operators in many countries are pushing the upper boundaries of LTE network speed in order to provide versatile services and attract more users. Moreover, the coverage of LTE network continues to expand to the point that 4G networks are now as ubiquitous as the preceding 3G networks. As a cost-effective method of expanding coverage and increasing capacity, Relay Node (RN) specified in LTE-Advanced [2] plays an important role to improve service for edge user (UE) equipment. However, introduction of RN also increases the complexity of radio resource management as well as packet transmission scheduling.

On the other hand, in order to be able to transmit in both the *uplink* (UL) and *downlink* (DL) directions, two duplex modes are defined in LTE, namely frequency division duplex (FDD) and time division duplex (TDD). FDD implies that DL and UL transmission take place in

different, sufficiently separated, frequency bands. In the case of TDD, there is a single frequency band only and UL and DL transmissions are separated in the time domain on a cell basis. Different asymmetries in terms of the amount of resources, i.e. subframes, allocated for UL and DL transmission, respectively, are provided through the seven different DL/UL configurations within a radio frame (10ms). From the aspect of resource allocation and transmission scheduling, TDD is more complicated than FDD.

Combining RN and TDD together makes the situation even more complicated. Issues that need to be dealt with include: (1) Dynamic TDD configuration for both the backhaul link (i.e. the radio link between the base station of DeNB and RN) and the access link (i.e. the radio link between RN and UEs), (2) Packet scheduling of the two-hop transmission for both DL and UL, (3) Interference mitigation among DeNB, RNs, and UEs, (4) Energy-saving techniques involving the user side as well as the network side, etc.

The authors have been researching energy-saving issues in wireless communication systems for some years. The idea of Load-Based Power Saving (LBPS) was originally proposed for IEEE 802.16 [3]. Extended LBPS schemes for LTE were also designed in our previous work [4]-[6]. In this paper, a more general and complicated network environment with multiple RNs under the same DeNB in the mode of TDD is considered, and power saving mechanisms integrating all RNs and the attaching UEs under each RN are proposed. As will be shown by the simulation study, high power saving efficiency for RNs and UEs can be achieved by the proposed schemes.

The remainder of the paper is organized as follows. In Section II, a brief survey of LTE-A RN and TDD related materials as well as the authors' previous work of LBPS is presented. Proposed schemes of power saving integrating RNs and UEs in LTE-TDD are presented in Section III. Performance evaluation is presented in Section IV. Finally, Section V concludes this paper.

II. RELATED WORK

A. LTE-A RN and TDD

One important feature of an RN is the carrier frequency it operates on. There are two methods of operation: Inband and Outband. An RN is said to be "Inband" if the backhaul link between the DeNB and the RN are on the same carrier frequency as the access link between the RN and UEs. For Outband RNs, the backhaul link operates of a different carrier frequency to that of the access link. Two basic types of RN are proposed, although there are subdivisions within these basic types: Type 1 and Type 2. Type 1 RNs appear as if they are a Release 8 eNB to Release 8 UEs for backwards compatibility and control their cells with their own identity



including the transmission of their own synchronization channels and reference symbols. The basic Type 1 RN provides half duplex with Inband transmissions. Type 2 RNs do not have their own cell identity and look just like the main cell. Any UE in range is not able to distinguish a Type 2 RN from the main eNB within the cell. This paper focuses on Type 1 RN.

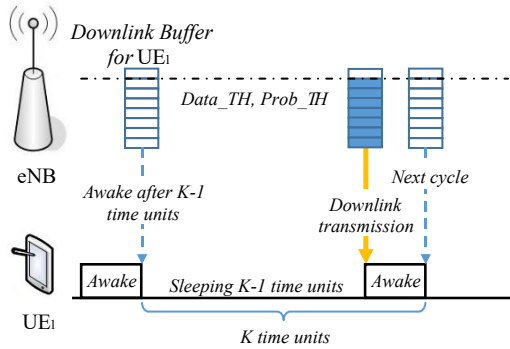

Fig. 1 Load-Based Power Saving

On the other hand, there are seven configurations of TDD defined in LTE as displayed in Table I, in which different numbers of DL and UL subframes are specified within a radio frame of 10ms in order to provide some flexibility in resource management for both directions. With the presence of Type 1 RNs in the mode of TDD, special MBSFN subframes (present in R8/R9 LTE standard for Multicast & Broadcast features) are used for the DL backhaul data transmission (from DeNB to RN). By configuring some of the access link subframes as MBSFN subframes, the RN can stop transmitting in the latter part of these subframes and receive transmissions from the DeNB. Due to the requirement of Type 1 RN in TDD that a subframe can only be used for the backhaul or the access link in either direction of DL or UL, as well as the requirement of MBSFN subframes and HARQ timing, there are 19 configurations specified by 3GPP for the backhaul link, as displayed in Table II. Note that subframes 0~1 and 5~6 cannot be configured as MBSFN subframes; therefore, they are ineligible to be used by the backhaul link, resulting that the configuration of the relay cell (i.e. the access link) in Table II does not include Configurations 0 and 5.

TABLE I
TDD CONFIGURATION IN LTE

DL/UL Config.	Subframe number									
	0	1	2	3	4	5	6	7	8	9
0	D	S	U	U	U	D	S	U	U	U
1	D	S	U	U	D	D	S	U	U	D
2	D	S	U	D	D	D	S	U	D	D

3	D	S	U	U	U	D	D	D	D	D
4	D	S	U	U	D	D	D	D	D	D
5	D	S	U	D	D	D	D	D	D	D
6	D	S	U	U	U	D	S	U	U	D

(Note: D: DL subframe, U: UL subframe, S: Special subframe)

Related research involving RN and TDD in the literature includes: (1) resource allocation and scheduling algorithms [7]-[9] to achieve high throughput while maintaining a certain level of fairness. (2) Interference mitigation techniques [10]-[12] for neighboring DeNBs and RNs. (3) Dynamic TDD configuration schemes [13]-[15] that can adapt to different traffic conditions in the heterogeneous network environment.

TABLE II
BACKHAUL AND RELAY CELL CONFIGURATION IN LTE-A TDD

Backhaul Subframe Config.	Config. in Relay Cell	Subframe Number									
		0	1	2	3	4	5	6	7	8	9
0						D					U
1						U					D
2						1					D
3								U	D		D
4								U	D	U	D
6						D				U	
7								U			D
8	2					D				U	
9								U		D	D
10								D			D
11								U		U	
	3									D	

12	U		D	D
	D			
13	U			
	D			
14	U		D	
	D			
15	4		U	
	D		D	
16	U			D
	D		D	
17	U D	D D D	18 6	U D

B. Previous Work of LBPS

The idea of LBPS is to make use of traffic modelling to determine the length of the sleep period. The traffic in LBPS is assumed to be *Poisson* process in order to take advantage of the multiplexing property. Taking a single UE with the downlink traffic as an example, the eNodeB estimates the traffic load and calculates the length of the sleep period in order for the accumulated data in the eNodeB's buffer reaching a predefined level as illustrated in Fig. 1. The predefined level consists of two threshold parameters: *Data_TH* and *Prob_TH*. The length of the sleep period is calculated by making the amount of accumulated data exceeding *Data_TH* with probability higher than *Prob_TH*. It is suggested to set *Data_TH* as the amount of data that can be served within a subframe in LTE, in order to get a good balance between power saving and delay performance. In LTE, the amount of data which can be served in a subframe is fluctuated and affected by the link quality. In the authors' previous work [4]-[5], Channel Quality Indicator (CQI) was used in estimating subframe capacity.

For the general case of multiple users in the network, three LBPS schemes namely LBPS-Aggr, LBPS-Split, and LBPS-Merge were proposed to deal with multiplexing UEs in sleep scheduling. LBPS-Aggr is the simplest scheme which treats all traffic as an aggregate flow in determining the length of the sleep period and synchronizes all UEs in sleep

III. PROPOSED INTEGRATED SLEEP SCHEDULING

A. Basic Idea

The network environment we are focusing on is as displayed in Fig. 2, in which multiple RNs ($RN_1 \sim RN_n$) are under the same DeNB, and a number of UEs are attaching to each RN. The configuration for the backhaul link is denoted by *Config-B*, and the configuration for each of the

scheduling. The other two enhanced LBPS schemes try to lengthen the sleep period by making UEs into different groups in sleep scheduling. Starting from the same position as LBPS-Aggr, LBPS-Split try to split the UEs into more groups until there is no space for further splitting. Taking the reverse direction of LBPS-Split, LBPS-Merge initially treats each UE as a single-member group and merges some of the groups until a feasible sleep schedule is found. Note that the cycle length for each group in LBPS-Merge is converted to the closest and smaller power of 2 in order to efficiently find a feasible sleep schedule for all groups. Please refer to the authors' previous work [3]-[4] for more details of the LBPS schemes.

Although based on the general idea of data accumulation according to the estimated input load and the estimated capacity in a subframe, sleep scheduling in the LBPS schemes was assigned by assuming the availability of every subframe in a continuous manner as in LTE-FDD.

Fig. 2 Overview of integrated sleeping scheduling for multiple RNs and UEs

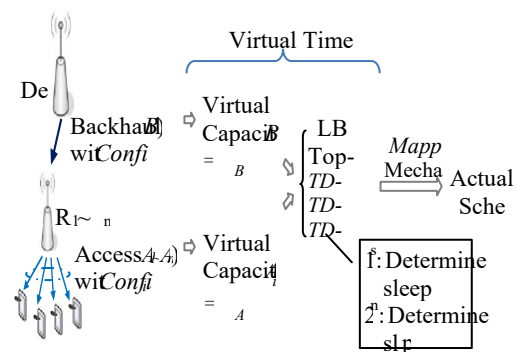

However, in the case of TDD, the availability of subframe for DL/UL transmission depends on the given configuration, and the algorithm of sleep scheduling needs to consider the pattern of available subframes. In order for the LBPS schemes to be applied in TDD, the idea of Virtual Time associated with the mapping mechanisms from virtual time to actual time for different TDD configurations was proposed [6]. Three mapping mechanisms, namely One-to-All mapping, Continuous mapping, and One-to-One First mapping, were investigated. Simulation study showed that One-to-One First mapping outperforms the other two mappings in terms of power saving efficiency.

access link ($A_1 \sim A_n$) is denoted by *Config-A_i* in the paper. In order for LBPS to be applied in the case of RN and TDD, the idea of Virtual Time is adopted, and Virtual Subframe Capacity (VSC) for both the backhaul link and the access links must be calculated. As illustrated in Fig. 2, based on the estimated VSC, a top-down approach for integrating sleep scheduling is adopted in the domain of virtual time, in which RNs' sleep schedule is first determined, and then the sleep schedule of the UEs under each RN is determined.

Finally, the sleep schedule in virtual time is mapped back to the actual time. Calculation of VSC, the top-down LBPS schemes, and the mapping mechanisms are presented in the following sections.

B. Calculation of Virtual Subframe Capacity

The purpose of Virtual Time is to create a time domain in which each subframe is continuously available for access in order for LBPS schemes to operate. The resource in a virtual subframe is allocated from the radio resource in the actual time domain according to the TDD configuration. As illustrated in Fig. 3, given *Configuration 17* for the backhaul link and considering DL only, the total amount of radio resource of the four DL subframes (i.e. subframe 4, 7, 8, and 9) is allocated equally to each virtual subframe. Moreover, due to the resource sharing property of Type 1 Inband RN, a DL subframe can only be used by either the backhaul link or the access link. On this matter, we assume the backhaul link is given the priority to use the DL subframe over the access link. Therefore, calculation of the average number of DL subframes available for the access link must exclude the average number of the same subframes used by the backhaul link, which depends on the utilization of the backhaul link. Calculation of the virtual subframe capacity for the backhaul link (denoted by VSC_{Bk}) and the access link (VSC_{Ai} for A_i) is presented as follows:

$$\begin{aligned}
 & \text{--- Avg. Subframe Capacity of Bk \#DL subframes in} \\
 & \text{Config-B } VSC_{Ai} \\
 = & \text{--- Avg. Subframe Capacity of} \\
 & \text{Avg. \#DL subframes in} \quad \text{\#DL subframes in Config-}A_i \\
 & \text{\#Same DL subframes} \\
 & \text{used by Bk} \times (\text{Backhaul Utilization}) \\
 & \text{(Backhaul Utilization)} \frac{\text{Total DL Input Load}}{\text{Total DL Capacity of Bk}}
 \end{aligned}$$

For example, given *Configuration 17* for the backhaul link (and *Configuration 4* for access link A_i), we have ($\#DL$ subframes in *Config-B*) = 4, ($\#DL$ subframes in *Config- A_i*) = 8 (Note that the special subframe is seen as a DL subframe for simplicity), and ($\#Same$ DL subframes used by Bk) = 4. Note that the estimation of the average subframe capacity (*Avg. Subframe Capacity of Bk* and A_i) is according to the system bandwidth, the allocation of the control channels, and the channel quality. Please refer to the authors' previous work [4] for details.

E.g. Configuration 17 for the backhaul link (DL only)

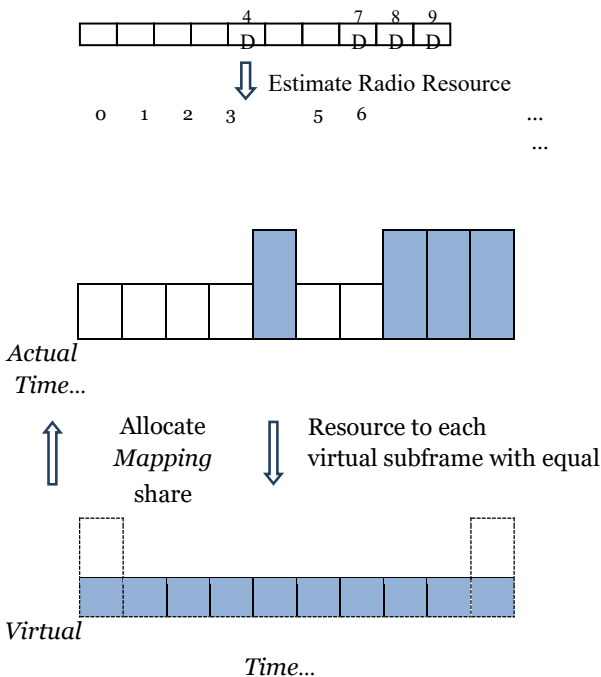

Fig. 3 The idea of Virtual Time

Fig. 4 E.g. First step in the proposed schemes

C. Top-Down LBPS Schemes

There are two steps in the top-down approach to integrate sleep scheduling for RNs and UEs in the virtual time domain. Firstly, the sleep schedule for all RNs on the backhaul link is determined by the LBPS schemes, and the UEs' sleep schedule on each access link is then determined. We assume that RNs' are properly deployed such that there is no interference among all access links, and the sleep schedule on each access link can be determined independently. Three LBPS schemes, namely TD-Aggr, TD-

$VSC_{Bk} =$

Split, and TD-Merge, in the top-down approach are designed in the paper.

In the first step, the sleep cycle for each RN on the backhaul link is calculated according to VSC_{Bk} and each RN's DL load. All RNs are treated as a group in sleep scheduling in *TD-Aggr*, and a number of groups is made in *TD-Split* and *TD-Merge* in order to maximize the sleep cycle length as in the authors' previous work. The threshold of data accumulation for each group in the schemes is set as the capacity of one virtual subframe on the backhaul link, i.e. VSC_{Bk} . Examples of the first step in each proposed schemes are displayed in Fig. 4. Note that the sleeping period obtained in the first step only indicates RN's behavior on the backhaul link, which should be brought together with RN's behavior on the access link of the second step to determine the final sleep schedule for each RN.

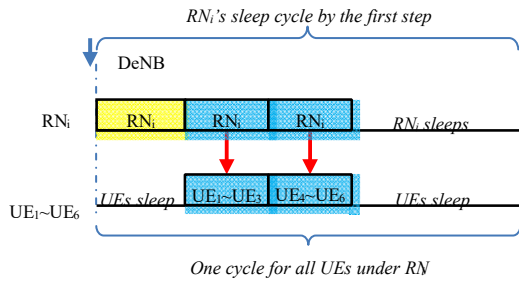

Fig. 5 E.g. Second step in the proposed schemes

Given the sleep cycle obtained in the first step, the second step to determine the sleep schedule for the RN and attaching UEs on the access link is similar for the three proposed schemes. As illustrated in Fig. 5, within the sleep cycle obtained by the first step, there is one subframe for RN_i to receive DL data from DeNB. In the second step, the RN needs to estimate the number of subframes to transmit all received DL data to the attaching UEs on the access link

combine the rest of the resource for allocation, as illustrated in Fig. 6 (b). Simulation study showed that One-to-One First mapping is better than Continuous mapping in terms of power saving efficiency. However, for the case of Type 1 RN in the network, there is one more problem to be addressed. An RN plays two different roles in two-hop DL transmission: receiver on the backhaul link and transmitter on the access link. As illustrated in Fig. 7, RN's two roles are scheduled in different

within one sleep cycle. The estimated number of subframes on the access link A_i , denoted by N_{Ai} , is calculated by dividing the expected amount of DL data for RN_i by the virtual subframe capacity of A_i (i.e. VSC_{Ai}) as presented in the following equation.

$$N_{Ai} = \frac{\left(\frac{\lambda_i}{\sum_{\forall RN_j \text{ in the same group of } RN_i} \lambda_j} \right) \times VSC_{Bk}}{VSC_{Ai}}$$

Note that since the DL data to each RN_j in the same group of RN_i in the first step contributes to the amount of VSC_{Bk} in the proposed LBPS schemes, the amount of RN_i 's data is calculated by weighting the input load of RN_i (denoted by λ_i) over the total load of all RNs in the same group. Also note that the value of N_{Ai} in the example of Fig. 5 is assumed to be two, therefore the UEs attaching to RN_i are separated into two groups in the sleep schedule.

Lastly, schedulability for each access link is checked by the following criterion: If $(1+N_{Ai}) \leq \text{the cycle length of } RN_i$, a feasible sleep schedule can be found for A_i , otherwise the LBPS scheme fails.

D. Mapping Mechanism

The mapping from a virtual subframe to the actual subframe(s) is determined by how the radio resource is allocated to the virtual subframe. Two typical methods of allocation were investigated in the authors' previous work [6]: Continuous mapping and One-to-One First mapping. In Continuous mapping, the available radio resource is allocated to each virtual subframe with the equal share of the total capacity in the continuous manner as illustrated in Fig. 6 (a). One-to-One First mapping goes for 1-to-1 mapping first and

virtual subframes, but different subframes could be mapped to the same actual subframe by the mapping mechanism, which forces the RN to choose only one role to perform. The problem is called RN collision, in the paper. The problem of RN collision should be avoided as much as possible since it reduces the performance either on the backhaul link or on the access links and creates unexpected results.

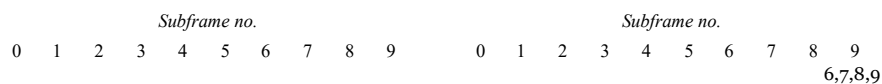

Fig. 6 Continuous mapping vs. One-to-One First mapping

4 4 4,7 7 7 8 8 8,9 9 9

Fig. 8 Continuous mapping for backhaul link of C17 subframes are non-access-only subframes. As illustrated in Fig.

Configuration 17 (C17) on the backhaul link, subframes 0, 1, 5, 6 are access-only subframes since they are not accessible on the backhaul link. The rest of DL subframes (i.e. subframes 4, 7, 8, 9) are non-access-only subframes. RN collision never happens in access-only subframes, therefore One-to-One First mapping is adopted for access-only subframes to maximize power saving efficiency. For non-access-only subframes, Continuous mapping is adopted to reduce the probability of RN collision.

Note that in Fig. 9, it is assumed that the DL utilization on the backhaul link is 0.5 in the example. Since the backhaul link is given priority over the access link in the paper, RN will receive data from the backhaul link on subframes 4, 7, 8, 9 for 50% of the time. Only for the rest of the 50% of time, RN can transmit data on subframes 4, 7, 8, 9, and the capacity of subframes 4, 7, 8, 9 on the access link is reduced by half.

IV. PERFORMANCE EVALUATION

Simulation study was conducted to evaluate the performance of the proposed mechanisms. There are six RNs under the DeNB and 40 UEs under each RN in the network. The CQI value for the backhaul link is randomly selected from the range of 10~15. Three types of the access link is defined: H-type, M-type and L-type. The CQI value for H-type is randomized from 10~15, M-type 7~9, and L-type 1~6. A contrast scheme, namely Std-DRX, is also simulated. The simulation parameters are summarized in Table III.

TABLE III
SIMULATION PARAMETERS

Channel capacity	20 MHz (#RB = 100)
(#RN, #UE under RN)	(6, 40)
Backhaul link quality	CQI 10~15
Access link quality	H-type: CQI 10~15, M: CQI 7~9, L: CQI 1~6
TDD Configuration	C17 (C4 for access links)
Packet Size	799 bits
LBPS schemes parameters	
DATA_TH	Estimated Capacity × Prob_TH

cannot be used by the backhaul link, and the rest of the 9, for an access link with Configuration 4 (C4) under

Prob_TH 0.8

Contrast scheme Std-DRX parameters

On duration = 1ms, Inactivity timer = 10ms, Short DRX Cycle = 80ms, Short Cycle timer = 1, Long DRX Cycle = 160ms.

Due to the limited space of the paper, only the performance results of Power Saving Efficiency (PSE), defined as the average ratio of time for RNs or UEs in the sleep mode, are displayed. The results of RN's PSE and UE's PSE for M-type access link are shown in Figs. 10 and 11, respectively, demonstrating the benefit of the proposed LBPS schemes in energy saving over the contrast scheme.

V. CONCLUSION

Extension of the authors' previous work of Load-Based Power Saving (LBPS) is proposed for LTE-A Relay Node (RN) environment under the mode of Time Division Duplex (TDD) in this paper. By adopting the idea of virtual time to deal with TDD configurations, three LBPS schemes in the top-down strategy, namely TD-Aggr, TD-Split, and TD-Merge, are proposed to integrate sleep scheduling for RNs and UEs. Mechanisms including calculation of the virtual subframe capacity, the integrated sleep scheduling algorithm, and the mapping mechanisms for the backhaul link and the access link, are designed in each proposed scheme. The benefit of the proposed LBPS schemes for both RN's and UE's power saving is demonstrated by the simulation study.

REFERENCES

- [1] 3GPP TS 36.300, "Evolved Universal Terrestrial Radio Access (E-UTRA) and Evolved Universal Terrestrial Radio Access Network (E-UTRAN)," Rel. 8, v8.5.0, May 2008.
- [2] 3GPP TS 36.300, "Evolved Universal Terrestrial Radio Access (E-UTRA) and Evolved Universal Terrestrial Radio Access Network (E-UTRAN)," Rel. 10, v10.3.0, Mar. 2011.
- [3] C.-C. Yang, Y.-T. Mai, J.-Y. Chen, Y.-S. Shen, and Y.-C. Kuo, "LBPS: Load-based Power Saving in the IEEE 802.16e Network," Computers and Electrical Engineering, vol. 38, no. 4, July 2012, pp. 891-905.
- [4] C.-C. Yang, J.-Y. Chen, Y.-T. Mai, and C.-H. Liang, "Adaptive Load-based and Channel-aware Power Saving for Non-Real-Time Traffic in LTE," EURASIP Journal on Wireless Communications and Networking, vol. 2015, Issue 1.

- [5] C.-C. Yang, J.-Y. Chen, Y.-T. Mai, and H.-H. Liu, "Integrated Power Saving for Relay Node and User Equipment in LTE-A," *International Journal of Communication Systems*, vol. 29, no. 8, May 2016, pp. 1342–1364.
- [6] C.-C. Yang, J.-Y. Chen, Y.-T. Mai, and Z.-Y. Pan, "Load-Based Power Saving for Downlink Non-Real-Time Traffic in LTE-TDD," *Proceedings, 2016 World Conference on Innovation, Engineering, and Technology (IET 2016)*, June 24-26, 2016, pp. 83-98, Sapporo, Japan.
- [7] Z. Ma, W. Xiang, H. Long, and W. Wang, "Proportional Fair Resource Partition for LTE-Advanced Networks with Type I Relay Nodes," *Proceedings, IEEE International Conference on Communications (ICC)*, June 5-9, 2011, pp. 1-5, Kyoto.
- [8] Z.Y. Zhao, J. Wang, S. Redana, and B. Raaf, "Downlink Resource Allocation for LTE-Advanced Networks with Type1 Relay Nodes," *Proceedings, IEEE Vehicular Technology Conference (VTC Fall)*, Sept. 3-6, 2012, pp. 1-5, Quebec City, QC.
- [9] X.-L. Wu, W.-J. Zhao, and W. Wu, "Throughput and fairness-balanced resource allocation algorithm in TD-LTE-Advanced relay-enhanced network," *Proceedings, International Workshop on High Mobility Wireless Communications (HMWC)*, Nov. 1-3, 2013, pp. 82-86, Shanghai.
- [10] L. Yang and A. Harada, "A spectrum allocation scheme for adjacent channel interference mitigation in relay backhaul link in coexisting FDD and TDD systems," *Proceedings, IEEE Wireless Communications and Networking Conference (WCNC)*, April 7-10, 2013, pp. 516-521, Shanghai.
- [11] Y. Yuda, A. Iwata, and D. Imamura, "Interference Mitigation Using Coordinated Backhaul Timing Allocation for LTE-Advanced Relay Systems," *Proceedings, IEEE International Conference on Communications (ICC)*, June 5-9, 2011, pp. 1-5, Kyoto.
- [12] W. Hong, J. Han, and H. Wang, "Full Uplink Performance Evaluation of FDD/TDD LTE-Advanced Networks with Type-1 Relays," *Proceedings, IEEE Vehicular Technology Conference (VTC Fall)*, Sept. 5-8, 2011, pp. 1 – 5, San Francisco, CA.
- [13] M. Ding, D. L. Pérez, A. V. Vasilakos, and W. Chen, "Dynamic TDD transmissions in homogeneous small cell networks," *Proceedings, IEEE International Conference on Communications Workshops (ICC)*, June 10-14, 2014, pp. 616-621, Sydney, NSW.
- [14] H. Liu, Y. Jiao, Y. Gao, L. Sang, and D. Yang, "Performance evaluation of flexible duplex implement based on radio frame selection in LTE heterogeneous network," *Proceedings, 22nd International Conference on Telecommunications (ICT)*, April 27-29, 2015, pp. 308-312, Sydney, NSW.
- [15] M. Malmirchegini, R. Yenamandra, K. R. Chaudhuri, and J. E. V. Bautista, "Distributed and Adaptive Optimization of LTE-TDD Configuration Based on UE Traffic Type," *Proceedings, IEEE 81st Vehicular Technology Conference (VTC Spring)*, May 11-14, 2015, pp. 1-6, Glasgow.