

# Distributed Energy Trading Mechanisms for Local Smart Grids: An Integrated Approach

Dr. Gilbert Strang

*Massachusetts Institute of Technology (MIT),  
USA.*

**Abstract**—This paper provides a view to Peer-to-Peer (P2P) approach for smart grid operation adopted in P2P-SmarTest project. It provides an overview on solutions proposed for distributed P2P energy trading, P2P grid control and wireless communication enabling the proposed P2P operation. The paper proposes some business models that can be adopted in a P2P setting. We also outline the barriers and enablers against and for adopting local or regional P2P based electricity operations.

## I. INTRODUCTION

Recently, there has been a rapid growth in Distributed Energy Resources (DER) such as distributed generation and energy storage connecting to the distribution network and microgeneration and flexible loads at the premises of end users [1],[2]. Estimates reveal that renewable energy sources based on solar, wind, geothermal and tides can meet a large portion of the energy demand [3]-[5]. These resources are not actively utilized at the distribution system by distribution network operators, retailers or energy service providers, as there are no active markets in place to incentivize DERs at the edge of the grid.

Therefore, results that demonstrate a smarter electricity distribution system integrated with advanced Information and Communications Technologies (ICT), regional markets and innovative business models are of essence. Our approach is to employ Peer-to-Peer (P2P) approaches to ensure the integration of demand side flexibility and the optimum operation of DER and other resources within the network while maintaining second-to-second power balance and the quality and security of the supply.

We propose a distributed approach to system design and will propose solutions to the objectives set above wherein we define solutions to P2P electricity trading, P2P grid control and distributed ICT. The rest of the paper is organized as follows: Section II will propose P2P based trading model and develops P2P advanced

optimization techniques to provide efficient P2P energy market trading. In order to fulfil a real integration of the flexibility of demand and DER management using P2P, the whole market domain will be briefly explored. Section III will propose P2P based grid control model and propose P2P based control paradigm for distribution networks, integrate probabilistic and predictive control functions to enable and facilitate the P2P based energy trading and better network operation under extremely dynamic and uncertain conditions, and model of dynamic demand for operational functions of P2P smart distribution networks. Section IV discusses existing ICT technologies in P2P setting and proposes adaptations to existing ones for (a) the optimized, stable and robust P2P energy trading. and balancing within a Microgrid, a CELL (a defined set of microgrids), and intra Microgrids and CELLS while considering the new business models, (b) active electricity network management, demand/response, load balancing and forecasting,

congestion management and capacity calculation and (c) optimum, secure and stable operation of a Microgrid and a CELL during normal/abnormal operating conditions. While the focus is on investigating the last-mile technologies which support inter- and intra-Microgrids operation, also the backbone telecom infrastructure is considered, which is critical for intra CELLS operation and data exchange with transmission network operators. Section V takes a look at the business in smart grids and formulates alternative business models assuming P2P energy trading to capture the whole supply chain value while maintaining second-by-second power balance, maximizing Demand Response and DER utilization and ensuring supply security.

## II. DISTRIBUTED ENERGY TRADING

A Microgrid (MG) is an integrated energy system consisting of DERs and multiple electrical loads within clearly defined electrical boundaries that acts as a single controllable entity with respect to the grid. It operates as a single, autonomous grid, either in grid-connected or islanded mode [6]. This paper considers that the commercial operation of the microgrid is managed by a virtual entity called microgrid trader. This entity may have commercial agreements with prosumers, other microgrid traders in the same cell (local grid) and Aggregators. On the other hand, the Aggregator is a legal entity that aggregates the load or generation of various demand and/or generation/production units to provide service to the wholesale market. In this work the term aggregation refers to the aggregation of loads and distributed renewable generation. Aggregation is a role that can be



met by existing market actors or can be carried out by a separate actor (Third-party Aggregator). This entity may have commercial agreements with Microgrid Traders, Transmission System Operators (TSOs), Distribution System Operators (DSOs) and prosumers.

The trading plane model that this paper is supporting and investigating is depicted in Fig. 1. The commercial relations supported by this P2P Trading Model are specified below:

**-Commercial relation between Microgrid Trader and Microgrid Traders:** Microgrids may trade energy with other microgrids. This trading is performed by the microgrid traders, which exchange bids and offers. In this trading, microgrids may interact with the Aggregators (as detailed below) and/or operate in islanded mode (i.e., disconnected from the main grid).

**- Commercial relation between Microgrid Traders and Prosumers:** A prosumer physically connected to a microgrid can have (or not) a contract with the microgrid trader in charge of its microgrid, in order to participate in the P2P Trading.

**- Commercial relation between Microgrid Traders and Aggregator:** Different commercial relations are envisaged. First, the microgrid trader can have (or not) a contract with a single aggregator in order to participate in the wholesale market. Besides, microgrid traders may establish commercial agreements with different aggregators to manage its local load

**Fig. 1. The P2P trading model**

(outsourcing of demand side management). As for the aggregators, these are allowed to have bilateral contracts with multiple microgrids and users for providing demand side management solutions to microgrids and energy discounts to users. Additionally, the aggregator can operate as a retailer for the microgrids granting their access to the wholesale market.

**- Commercial relation between Prosumers and Aggregator:** Prosumers within the microgrid could have contracts with an aggregator in order to participate in the wholesale market. The participation of the prosumer in the wholesale market includes: sell/buy generation and sell/buy consumption (sell means increase consumption for example with storage / buy means decrease consumption by DER). Besides, prosumers may also have commercial agreements with aggregators to provide services to its microgrid trader or to the DSO.

**- Commercial relation between Aggregator and DSO & wholesale market:** The aggregator will provide services to wholesale market and to the DSO. In order to provide services to a DSO, it will use resources from prosumers and microgrid traders connected to the correspondent DSO's Cell. To provide services to the wholesale market the aggregator can use its whole portfolio of microgrid traders and individual prosumers. In Fig. 1 we also introduce a new key element which would be the P2P-Trading platform. This platform, besides

operating as marketplace providing information and matching buyers and sellers, can allow the self-regulation of the P2P Trading business acting as internal rule maker as the unique responsible in front of the "external world". The technology of the proposed P2P-Platform could be as innovative as desired. For example, Blockchain [28] could be used to ensure safety and reliability.

The P2P-Aggregator could be the entity playing the role of the P2P-Trading Platform Operator. For residential prosumers, the P2P-Platform will be bi-directionally connected to the Home Energy Management System. This two-way, end-to-end communications capability requires only Internet as common network. At the other end of the P2P chain, the rest of the peers which can be defined as "more intelligent": industrial loads, Microgrid Traders, P2P-Aggregator, they will be able to connect to the P2P-Platform without trouble through their Control Systems.

Using this Platform, at each level of the P2P-Trading, the peer buying a service can implement any specific set of rules to measure and verify the compliance of the demand response actions taken by the selling peer. We assume that the requirements established by System Operators will be the most demanding and critical. From this maximum, the requirements among peers will vary depending on the established contracts. All the criteria for the different steps in the M&V process [7] (procedures of qualifying a peer as DR provider, methods to calculate baseline, methods to measure actual consumption, frequency of real-time readings, accuracy of measures used for settlement, ...) will be agreed by each pair of peers taking

part in the transaction and the P2P-Platform will be able to support them with no technical limitations.

### III. DISTRIBUTED GRID CONTROL

In the control plane, to face the challenges of the control

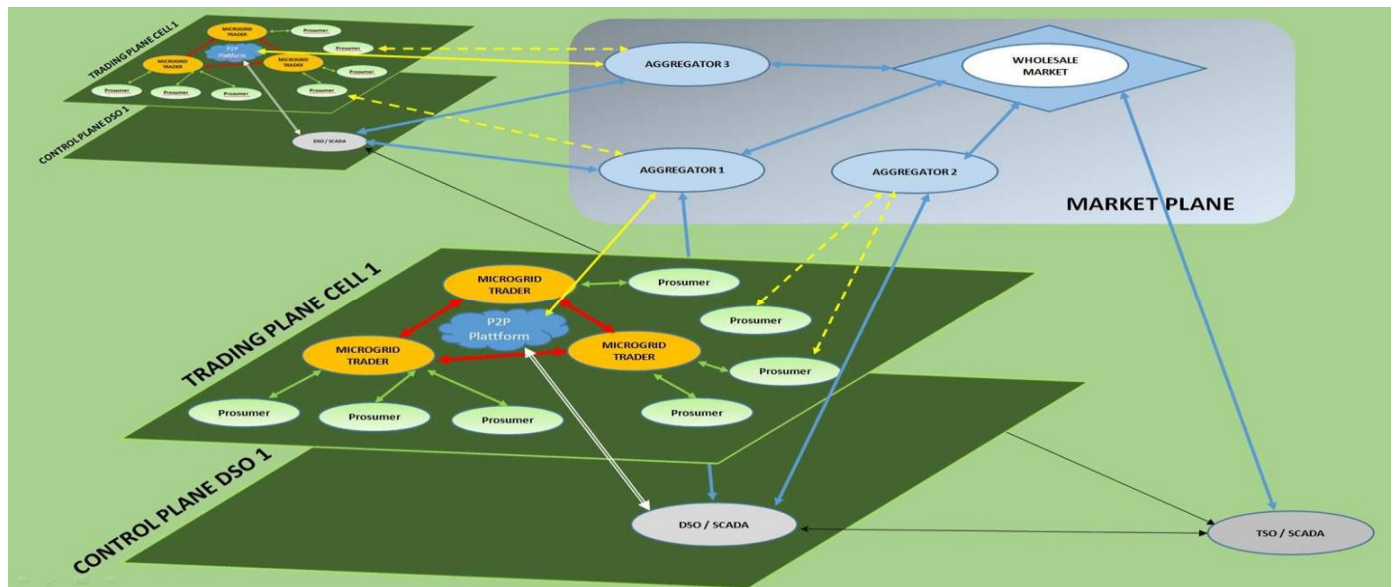

As we can see, at the heart of our P2P set-up is the Microgrid Trader. We have proposed a fully distributed trading mechanism [8], [9], in which MG traders interact between each other in order to reach consensus on the energy amounts to be exchanged and their respective prices. The proposed algorithm is versatile and may handle micro-generation and the flexibility (including DR and storage) of prosumers. The pseudocode of the P2P trading mechanism is given below.

**Algorithm 1. Distributed MG trading algorithm**

```

Each MG trader initializes its energy price.
Repeat
MG traders exchange energy prices.

Given the current energy prices:
Each MG trader decides the total energy that it wishes
to sell to other MG traders.
Each MG trader decides the energy it wishes to buy
from other MG traders and sends them the desired
energy bid.

Each MG trader computes the new energy price to
balance the total sold energy with the total energy that
other MG traders are willing to buy. Until convergence
condition is verified.
    
```

When the algorithm converges, the energy prices are the ones that balance offer and demand within each MG. Additionally, the obtained prices and energy bids are the ones that minimizes the total energy generation and transfer costs. We analytically prove that all microgrid traders are incentivized to participate in the trading process as they always minimize their costs.

of distribution networks with widespread of DERs, an alternative control paradigm [10] is proposed to apportion the distribution network into different zones in a form of hierarchical structure, and they are Microgrids, Cells (multi-Microgrids), and multi-Cells. Based on these control zones, the P2P approach is defined as a flexible energy trading between peers that contain many small-scale DERs, including those in the consumer homes. The P2P approach will promote regional energy trading and demand response to available resources in local areas, which requires an advanced ICT infrastructure. The proposed methodology is seeking to balance generation and demand in the lower level. The unbalance from the lower level will be traded with other peers in one-step higher level. This is considered as a more effective energy trading from the bottom level to upper levels. This method will stimulate the flexible demand to response to the resources when the prices from neighboring peers are reasonably cheaper than the higher level or the energy suppliers.

The project also investigates the impacts of DERs on the voltages and proposes advanced control algorithms to maintain the voltages within the accepted limits. A large penetration of DERs may create difficulty of maintaining the quality of supply voltage offered to all customers connected to the microgrids. When the load on the network is at a minimum, the generated power of the DERs can reverse the power flows in the grid, what could lead to a rise of the voltage profile beyond its allowed limits [11]. Besides, significant voltage drops can occur due to power losses in the feeders [12].

Multi-agent systems [13] can be used to set up a suitable control for power systems as they allow sections or devices to work autonomously. "A peer" proposed is then considered as "a control agent" and a decentralized P2P control method is considered. Therefore, the grid can operate in an autonomous way, in which each agent can

provide a certain control function. Agents are able to communicate with each other, creating possibilities to disseminate information about the state of the grid, without the need for one central point of information. A gossiping-based control algorithm is also proposed, where a

decentralized control can be used which also coordinates the primary control, secondary control and tertiary control in different time scales.

Fig. 2 shows a distributed P2P control strategy that is proposed for the control of distribution networks. The distribution network is divided into several microgrids, hierarchically organized at different voltage levels. A microgrid usually consists of a couple of low voltage feeders, physically connected to the same transformer, or a part of the medium voltage network at the same voltage level. On the connection points of two microgrids there is a coupling agent which serves as gateway of one microgrid to the other microgrid, the point of common coupling. As the microgrids represented in this figure are separated by transformers or substations, these would be good candidates for such a coupling agent. Such a coupling agent represents the characteristics of the whole lower level microgrid (e.g. a low voltage feeder) on the higher level microgrid (e.g. a medium voltage distribution grid). The agents are each able to communicate with some other neighboring agents in a P2P way, creating possibilities to disseminate data about the state of the grid without the need for one central point of information.

Solutions of using different potential control functions under P2P control paradigm to mitigate the technical issues in distribution networks were investigated. These control functions include network reconfiguration, coordinated voltage control, demand side management, and congestion and capacity management. Solutions to these include DER.

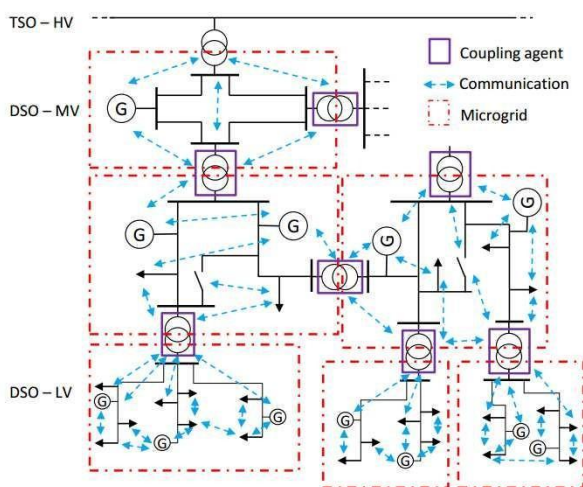

**Fig. 2. Proposed distributed P2P control strategy (P2P Control Model)**

- Feasibility of P2P energy trading and local demand supply balance of distribution networks was

assessed using smart metering data. An optimization method was used to find the optimal capacity of different DERs to maximize the local demand and supply balancing [14].

- Power electronic devices, e.g. Soft Open Points (SOPs), were used in distribution networks to mitigate voltage exclusion, thermal overloading and control power flows. The use of SOPs is able to significantly increase a distribution network's hosting capacity of distribution generation [15].

- Two decentralized voltage control algorithms were introduced to control the voltage within limits by use of a change in active and/or reactive power of DERs installed in the distribution grid itself. Both algorithms are based on an optimization problem, which is distributed over all agents participating in the voltage control. The first has as objective the minimization of the voltage deviations beyond limits, uses a gradient descent [16]. The second algorithm has as objective the minimization of active and reactive power, with constraints the voltages that have to be within limits. It uses a dual decomposition to distribute the optimization [17].

The algorithms are able to operate in a distributed manner thereby keeping all control local and eliminating any single point of failure. The algorithm can be executed asynchronously, with limited data exchange between the agents.

Both algorithms use a gossip-based push-sum protocol to dynamically disseminate all voltages (first algorithm) at the controlled nodes of the grid and the Lagrangian multipliers (second algorithm) to all participating agents, in a robust way.

#### IV. DISTRIBUTED ICT SOLUTIONS

We have developed and prioritized key performance indicators (KPIs) for P2P energy trading and control communications in [18]. Based on the prioritization the most important KPIs are: latency in critical situations, reliability of communications, security, robustness of technology, investment costs, number of supported users, and scalability. Latency in critical situations does not apply to energy trading communications, but it does apply in grid control [29], especially if primary control communications are targeted. Based on the general system model developed for P2P energy trading and grid control, we first develop the communication system model and identify the suitable technologies for each communication link defined in the system model. In this work, we mostly constrain ourselves to modifications of existing ICT solutions for transitional purposes. Proposed communication technologies are fixed Internet infrastructure, LTE network [30], device-to-device (D2D) communications in LTE network, and hybrid sensor – LTE solutions where clustered sensor networks are connected with LTE capable coordinators that relay the traffic between agents [20].

For P2P energy trading, D2D is only investigated for range extension and intermittent connectivity preservation of LTE technology for users that lack sufficient LTE signal coverage, as D2D communications is not really required for service provisioning. Today primary grid control does not rely on communications. There are indications that communication can provide benefits of better primary control for smart grids [19] and hence, ultra-reliable low-latency D2D is investigated as a communications link for primary control applications. Meanwhile, in secondary control, D2D in licensed spectrum is proposed for data exchange between agents in distributed grid control applications. D2D is perceived as an important functionality in the fifth generation telecommunications network and will be a service without additional deployment or operational costs. However, the functionality is not a part of current LTE networks.

In P2P energy trading wireless communications are most applicable between the prosumers and the microgrid traders. In most other cases fixed Internet infrastructure already exists and may be used. In P2P grid control wireless communications enable direct communications between agents within a microgrid. Considering the Reliability KPI, minimum requirements on data delivery ratio is 98% for automatic meter reading (AMR) and 99.5% for demand response and distribution automation. In most cases, LTE and hybrid sensor – LTE solutions achieve the required reliability [20] for both trading and grid control. By using D2D communications [21] or hybrid automatic repeat request in LTE (specified, but not used in general) the reliability can be increased further, close to carrier-grade communications. The security KPI comes as an inherent property of cellular networks for both trading and grid control when LTE or D2D communications is used. For hybrid sensor – LTE, solutions like IEEE 802.15.9 key management protocol need to be used to guarantee the sensor network part. Robustness KPI is mainly a hardware feature and difficult to take into account from the communications point of view. Using existing and tried hardware, when possible, in the introduction of new protocol code is one way to minimize impact of new features on robustness. Self-healing networks are another, but in terms of energy trading communications on peer-level, a malfunctioning device may be difficult to compensate for. D2D communications alleviate the problem if telecommunications infrastructure localized failures.

Cost KPI is an adoption barrier. The benefits of a given technology must outweigh both capital and operational expenses. P2P trading and control requires a high penetration to be useful so it is not possible to have a high cost per device with the capillarity that it is foreseen. Relying on technologies driven also by other application verticals enables reduction of costs. This is one of the primary reasons utilization of LTE components and D2D as an added-value 5G component. The number of

supported users KPI favors hybrid sensor – LTE and D2D solutions as the LTE random access channel does not cope well with huge number of simultaneous users [21],[22]. Both hybrid and D2D solutions can, at least theoretically, support the KPI. The scalability KPI relates to ease of installation and addition of new devices. Even though all of the technologies can auto-configure themselves to join their respective networks, trading and grid controls need to be offered as a service to ensure scalability. With regards to emergency and critical event latency KPI, the last gasp messaging in energy trading can be readily satisfied by all the solutions [21], [22]. For primary grid control, direct D2D communications between control agents is the only solution out of the considered solutions providing systematic latency close to the 10 ms delays required for e.g., protection circuitry operations.

## V. BUSINESS MODELS

The previous sections described how P2P energy exchange and trading can create value and opportunities for existing incumbents and new actors. A paradigm shift from viewing smart grid as a technology platform into viewing it as a business ecosystem has also emerged in P2P SmartTest research. In this regard, there is a need to shift from the firm-centric business model to ecosystemic business mode. Looking at business model conceptualizations in general, many of the modern frameworks are created at the company level [23], which serves business cases like utility-centric business model well [24]. However, it is identified as less suited for analyzing the interdependent nature of the companies and actors that are evolving in the same business ecosystem [25]. In [26] a suggestion is made that when working together, business ecosystems allow companies to create value that no single company could have created alone. Thus, the business ecosystem is imperative to the emergence of P2P energy paradigm.

### A. P2P ecosystemic model: The P2P energy platform

At ecosystem level, P2P energy trading can be seen as a platform. This platform operates as the marketplace providing information and matching buyers and sellers, enabling the selfregulation of the P2P exchanging through the platform. The creation of a P2P energy platform is not simply a creation of a technology or software package, it requires a systemic approach of value creation by facilitating the energy and price exchanges between two or more interdependent actors in the P2P ecosystem, such as consumers and energy generators. This platform must provide a secure and efficient marketplace for both, sellers and buyers. By inheriting the network effects and next generation communication technologies (e.g. 5G), platform is able to scale in the way that is not possible for traditional energy businesses.

The operating mode of the platform is to routinize a series of transactions on P2P marketplaces through

information systems, including user authentication, account verification, credit reporting, settlement, which would increase standardization, improving security and trust.

The platform web portal contains databases and search engines with filtering systems to automatically match user's request according to pre-specified criteria, improving effectiveness and better decision making, reducing transaction costs, reducing uncertainty, and creating transparency of the energy market.

The revenue source of the P2P platform comes from charge of transaction, membership fee and value added service compared to the traditional energy retailing business model that focus primarily on trading energy as a commodity.

### B. P2P Supplier model

The role of supplier is re-defined in P2P smart grid, in fact it can be taken by a group of actors, including traditional energy actors (retailers and Energy Service companies (ESCOs)), and new actors (P2P Aggregator and Microgrid Trader). The P2P supplier is defined as follow: "The Supplier is a grid user who has a grid connection and access contract with the TSO or DSO and also has a contractual agreement with end customer relating to the supply of electricity. When acting as Balance Responsible Party (BRP) the Supplier is responsible for acquiring the needed electricity for each operating hour for all customers they are balance responsible for."

Furthermore, suppliers also provide value-added products or services such as selling efficient household electrical appliances or smart home appliances, energy efficiency services and maintenance or insurance contracts, and procure aggregation of demand by combining multiple short-duration consumer loads for sale or auction in organized energy markets.

Two new supply actors are proposed by P2P SmarTest: P2P aggregator and Microgrid Trader, which are described and discussed below.

**P2P Aggregator:** The role of a P2P Aggregator can be carried out by different actors, e.g., by a traditional retailer, a Mobile Network Operator (MNO) or an independent aggregator. P2P Aggregator can act as service provider of aggregated DR or as the P2P Platform maker. Examples of the potential services provided by P2P Aggregator may include: marketing and customer engagement services, market analytics, demand and renewable forecasts, network flexibility capacity forecast, demand response forecast of aggregated load.

Through the project, we have also identified that incumbent supplier (retailer, ESCOs) has good position to play the role of P2P Aggregator as an actor in the P2P trading plane (as shown in Fig. 3). Since incumbent supplier already has a commercial relation with the prosumers and therefore, it has a deeper knowledge of their behaviors and interests. On the other hand the

technology infrastructure of P2P Trading is already or partially available for incumbent suppliers. Moreover, incumbent suppliers have established expertise on the rules and operation of the wholesale market.

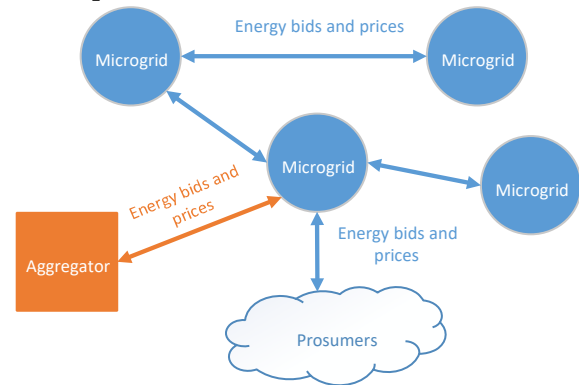

Fig. 3. Interaction of the different players at the trading plane.

**Microgrid Trader:** One of the novelties brought by the P2P- SmarTest project is the new agent called Microgrid Trader. The main business of the Microgrid Trader is to supply energy to the customers connected to the microgrid, either using the local generation resources available or purchasing the extra electricity outside of the microgrid. Also sometimes, if the electricity produced within the microgrid is bigger than the internal consumption, there would be a surplus of power within the microgrid that would be sold outside.

Microgrid Traders can trade energy locally with other Microgrid Traders in a P2P fashion (See Algorithm 1) and interact with the wholesale market through the aggregator (see Fig. 3).

When trading within the microgrid, the Microgrid Trader would sell electricity to the customers connected in a retail fashion, offering competitive tariffs due to its knowledge of local generation/consumption patterns and the reduction in transmission and distribution fees. These Microgrid Trader's clients could easily become prosumers. The consumers and prosumers of the microgrid would benefit of cheaper tariffs helping to reduce their electricity expenditure, getting better rate for either buying or selling energy. In addition, Microgrid Trader may also participate in DR and capacity markets.

### C. Alternative DSO model

Currently, DSOs own, operate and manage regional electricity distribution networks. Their job to a large extent is to deliver "always-on" electricity. However, the landscape of energy is changing, and the drivers may include: distributed generations, demand response, electric vehicles (EVs), energy storage, which increase system imbalances, congestions, power quality and need for distribution network reinforcements. P2P energy platform is envisioned to bring new DSO actor on top of the traditional DSO business model. DSO may have a shared network access (SNA) as new scheme. The SNA

incentivizes the incumbent DSOs to give up its exclusive access to the network, leasing the spare capacity or back up capacity to licensed independent parties. The ownership of assets will be retained by the incumbent DSO while competition will be introduced in the operation of the spare capacity. The independent parties who have license for SNA will act as secondary DSOs to provide flexible network services using the spare capacity in the network, thus substantially reduce the network access cost for flexible demand.

The key driver of SNA is the ever increasing number of flexible demand connected to the distribution networks with requires huge investment from the incumbent DSO. A substantial amount of capacities is designed to support the temporary system peak while maintaining under-utilized capacity most of the time. The result from P2P-SmarTest shows an option for network sharing between the incumbent and secondary DNOs, identifying that secondary DNOs could maximize the use of spare capacities.

## VI. BARRIERS AND ENABLERS

The current marketplace and regulatory framework will need some changes to allow for large scale deployment of P2P philosophy in electricity networks. Furthermore there are technological and social or engagement issues to be dealt with. In this section we provide a discussion on the above mentioned four categories. A more detailed discussion on barriers and enablers is available at [27].

**Regulatory:** It is considered that tax credit for households on installation work costs, and tax credit for small scale production are crucial enablers for the development of P2P energy market and corresponding business models. Also, particularly in the circumstance of Finland and other similar markets, the lowering investment barriers for households, which are already available for some forms of micro-production and governmental policies requiring standardized smart home/house technologies in all new buildings might become future enabling factors. In terms of barriers and limiting factors, uncertainties are the main issue: transparency of regulation, legislation and rules regarding government supports, differences between areas, reliability of technical solutions and savings projections, and data security and privacy.

**Commercial:** Major business obstacles and drivers to the development of P2P business models are to a large degree related with the regulatory and technical factors. In other words, for P2P trading, the inherent hurdles to unlock the flexibility of the demand or the well-studied barriers for local energy must be studied. Other barriers include: weak value proposition, the relatively high cost of implementation, lack of customer trust, and lack of consumer information and understanding.

**Technological:** The transition to a low carbon energy system have brought a series of smart grid technologies for

the low voltage (LV) distribution system. From this perspective, the enablers include the increasingly higher penetration of photovoltaics (PVs), heat pumps, and EVs, enhanced monitoring and planning on distribution levels, active network management on high voltage (HV) and extra high voltage (EHV) levels, and also the possibility of distribution system balancing. Main barriers in this domain include: the lack of monitoring and control devices particularly on LV distribution networks at this moment, network operating issues caused by DERs, such as voltage and frequency instability, security of supply, increased fault current levels and even more difficult demand forecasting.

**Social:** Understanding the values that influence consumer choices is of critical importance to motivate consumers to change behaviour and adopt P2P concepts. Key enablers include: the reduction of and control over electricity bills, environmental concerns, and better comfort such as the technological solutions allowing the optimization of comfort and more control over own energy use. However, mishandling of a number of elements might lead to consumer's reluctance of accepting new energy innovations: cost barriers, consumer awareness, control and privacy, trust, security and reliability, health concern, behavioural barriers, user experience and ease of use.

## VII. CONCLUSIONS

This paper proposes solutions targeting P2P system design for smart electricity grid. We target all three important layers of the smart grid, namely, electricity trading, grid control and communications and we provide a review of the results obtained in P2P-SmarTest project. The results indicate that P2P philosophy is well suited and even preferred solution when a large number of small scale distributed energy resources will be connected to the grid.

## REFERENCES

- [1] European Commission, "Smart Energy Grids and Complexity Science", Joint Research Centre Institute for Energy and Transport, 2012.
- [2] Danielle Devogelaer et al, "Towards 100% renewable energy in Belgium by 2050," Federal Planning Bureau (FPB), the Institut de Conseil et d'Etudes en Développement Durable (ICEDD) and the Vlaams Instituut voor Technologisch Onderzoek (VITO), 2nd edition: 19th of April 2013.
- [3] H Lund and BV Mathiesen, "Energy system analysis of 100% renewable energy systems—The case of Denmark in years 2030 and 2050", *Energy*, Volume 34, Issue 5, Pages 511-732, May 2009
- [4] B.V. Mathiesen et al., "Smart Energy Systems for coherent 100% renewable energy and transport solutions", *Applied Energy*, Volume 145, 1 May 2015, Pages 139–154
- [5] G. Pleßmann, M. Erdmann, M. Hlusiak, and C. Breyer "Global Energy Storage Demand for a 100% Renewable Electricity Supply", *Energy Procedia*, Volume 46, 2014, Pages 22-31

- [6] R. H. Lasseter, "MicroGrids," *Power Engineering Society Winter Meeting*, 2002. IEEE, 2002, pp. 305-308 vol.1
- [7] Deliverable D4.1: "Certification Mechanisms to measure the confidence and reliability of the energy transactions", Peer to Peer Smart Energy Distribution Networks (P2P-SmarTest), H2020 Project contract no. 646469, October 2016.
- [8] D. Gregoratti and J. Matamoros, "Distributed Energy Trading: The Multiple-Microgrid Case," in *IEEE Transactions on Industrial Electronics*, vol. 62, no. 4, pp. 2551-2559, April 2015.
- [9] M. Gregori, J. Matamoros and D. Gregoratti, "Demand Response Aggregators in Microgrid Energy Trading", to appear in *IEEE GlobalSIP* 2016.
- [10] H. Almasalma, J. Engels, and G. Deconinck, "Peer-to-peer control of microgrids," in *IEEE Benelux PELS/PES/IAS Young Researchers Symposium*. KU Leuven, 2016, pp. 1-6.
- [11] M. A. Mahmud, M. J. Hossain and H. R. Pota, "Analysis of voltage rise effect on distribution network with distributed generation," *IFAC Proceedings*, vol. 44(1), pp. 14796-14801, 2011
- [12] G. M. Miller and L. W. Robbins, "Fundamental Relations of System Voltage Drop and System Loads [includes discussion]," in *Transactions of the American Institute of Electrical Engineers. Part III: Power Apparatus and Systems*, vol. 74, no. 3, pp. 267-273, 1955.
- [13] S. D. J. McArthur, E. M. Davidson, V. M. Catterson, A. L. Dimeas, N. D. Hatziaargyriou, F. Ponci, and T. Funabashi, "Multi-agent systems for power engineering applications—part i: Concepts, approaches, and technical challenges," *IEEE Transactions on Power Systems*, vol. 22, no. 4, pp. 1743-1752, Nov 2007.
- [14] C. Long, J. Wu, and C. Zhang, "Feasibility of peer-to-peer energy trading in low voltage electrical distribution networks", *International Conference on Applied Energy*, ICAE 2016, Beijing, China, 8-11 Oct 2016
- [15] W. Cao, J. Wu, N. Jenkins, C. Wang, and T. Green, "Benefits analysis of Soft Open Points for electrical distribution network operation," *Applied Energy*, 165(1): 36-47, 2016.
- [16] Jonas Engels, Hamada Almasalma and Geert Deconinck, "A distributed gossip-based voltage control algorithm for Peer-to-Peer microgrids," in *2016 IEEE International Conference on Smart Grid Communications (SmartGridComm): Control and Operation for Smart Grids, Microgrids and Distributed Resources (SmartGridComm2016-Control)*, Sydney, Australia, Nov. 2016, pp. 376-381.
- [17] Hamada Almasalma, Jonas Engels and Geert Deconinck, "DualDecomposition-Based Peer-to-Peer Voltage Control for Distribution Networks," CIREN 2017, accepted
- [18] Deliverable D3.2, "Key performance Indicators for P2P energy trading communications," Peer to Peer Smart Energy Distribution Networks (P2PSmarTest), H2020 Project contract no. 646469, March 2016.
- [19] Y. J. Cheng and E. K. K. Sng, "A novel communication strategy for decentralized control of paralleled multi-inverter systems," *IEEE Transactions on power electronics*, vol. 21, pp. 148-156, 2006.
- [20] J. Markkula and J. Haapola, "LTE and hybrid sensor-LTE network performances in smart grid demand response scenarios," in *2013 IEEE International Conference on Smart Grid Communications (SmartGridComm)*, IEEE, 2013, pp. 187-192.
- [21] Deliverable D3.3, "Device-to-device and hybrid sensor – telecom infrastructure specifications for smart energy grids," Peer to Peer Smart Energy Distribution Networks (P2P-SmarTest), H2020 Project contract no. 646469, October 2016.
- [22] J. Markkula and J. Haapola, "Impact of smart grid traffic peak loads on shared LTE network performance," in *2013 IEEE International Conference on Communications (ICC)*, IEEE, 2013, pp. 4046-4051.
- [23] A. Osterwalder and Y. Pigneur, *Business Model Generation: A Handbook for Visionaries, Game Changers, and Challengers*. Hoboken, New Jersey: Wiley, 2010.
- [24] Y. Xu, M. Kopsakangas-Savolainen, P. Ahokangas, and F. Li, "Ecosystemic Business Model and Value in the Peer-To-Peer Smart Grid," in *Global Energy Interconnection 2016*, 2016.
- [25] K. Alanne and A. Saari, "Distributed energy generation and sustainable development," *Renew. Sustain. Energy Rev.*, vol. 10, no. 6, pp. 539-558, 2006.
- [26] R. Adner, "Match Your Innovation Strategy to Your Innovation Ecosystem Match Your Innovation Strategy to Your Innovation Ecosystem," *Harv. Bus. Rev.*, 2006.
- [27] Deliverable D2.2: "Regulatory, Business, Technological, and Social Enablers and Barriers of P2P Energy Transfer", Peer to Peer Smart Energy Distribution Networks (P2P-SmarTest), H2020 Project contract no. 646469, October 2016.
- [28] S. Nakamoto, "Bitcoin: A Peer-to-Peer Electronic Cash System" available at <https://bitcoin.org/bitcoin.pdf>, 2008
- [29] C. Kalalas, F. Vazquez-Gallego and J. Alonso-Zarate, "Handling missioncritical communication in smart grid distribution automation services through LTE," *2016 IEEE International Conference on Smart Grid Communications (SmartGridComm)*, Sydney, NSW, 2016, pp. 399-404.
- [30] C. Kalalas, L. Thrybom, and J. Alonso-Zarate, "Cellular Communications for Smart Grid Neighborhood Area Networks: A Survey," *IEEE Access*, vol. 4, no. 1, pp. 1469-1493, Apr. 2016