

Optimizing Biogas Yield: Real-Time Methane Production Monitoring Using Microcontroller- Based Technology

Aliyah R. Khan, Fatima M. Elsayed, Omar
A. Hassan

Department of Environmental Engineering, King Fahd
University of Petroleum and Minerals, Dhahran, Saudi
Arabia; Department of Electrical Engineering, Cairo
University, Cairo, Egypt

Abstract—Extracting energy from biomass is an important alternative to produce different types of energy (heat, electricity, or both) assuring low pollution and better efficiency. It is a new yet reliable approach to reduce green gas emission by extracting methane from industry effluents and use it to power machinery. We focused in our project on using paper and mill effluents, treated in a UASB reactor. The methane produced is used in the factory's power supply. The aim of this work is to develop an electronic system using Arduino platform connected to a gas sensor, to measure and display the curve of daily methane production on processing. The sensor will send the gas values in ppm to the Arduino board so that the later sends the RS232 hardware protocol. The code developed with processing will transform the values into a curve and display it on the computer screen.

I. INTRODUCTION

G

LOBAL warming is now an international issue, and reducing greenhouse gas (GHG) emission became the number one occupation of the industrial countries since pollution is mainly related to energy consumption[1].The electricity sector can be helpful in reducing anthropogenic GHG emissions since 40% of global GHG emissions are related to electricity production using fossil-fuel based materials. Hence, clean energy resources, mostly solar, wind, hydro and biomass are proposed as promising alternatives for electricity production [1].

Morocco, being a country importing almost all its energy needs, has made renewable energies for some years a strategic choice to meet its needs [2]. One of the major priorities of the new energy strategy is to increase the contribution of renewable energies to 42% of electricity generation by 2020 [2]. Many power plants are already running either solar, hydro, or wind farms; however,

biomass has also its important share in the Moroccan strategy plan [2].

Producing energy from waste seems like a good idea to reduce green gas emission [3], create energy, and use the residue called digestate rich in nutrients as a fertilizer for the soil, which made us keen on developing new ways of upgrading biogas production systems and developing new approaches to help us to monitor their production as well [3].

The integrated management of production by an automatic monitoring system provides important supervision and planning functions that ensure continuous and efficient operation of the plant. The device realized in our project will

display at any moment on the screen of a computer a curve showing the production of biogas (CH_4) as a time function. The program automatically warns the instructor of the methane production evolution by setting an alarm in case of an increase or deficit in produced quantity.

II. METHODOLOGY AND EXPERIMENTAL SETUP

A. Upflow Anaerobic Sludge Blanket (UASB) Biodigester

The anaerobic treatment of industrial wastewater gained much interest in the new approach of environment protection program, by reducing the green gas emission, and powering machines from trash [4]. Many effluents are becoming study subjects for a better biogas production, including paper and mill industry [4], [5]. It is one of the most water consuming industries in Morocco [2]; however, the effluents discharged are mainly thrown in the large sea near the industrial plants. Transforming the effluents into energy seemed like a good idea to reduce the factory's energy bill and protect the environment [4], [5].

The production of biogas requires certain parameters which must be well studied in order to obtain a good result.

We simulated a bio digester that will be heated using a solar collector system. The most important parameter taken into account is the temperature to ensure the smooth progress of the biogas production. In a previous work, the experiment consists on maintaining a temperature which satisfies the mesophilic condition for an optimum production of biogas (between 30 and 45 °C), the study is made to optimize the conditions necessary to produce an important level of methane[6], [7].

The biodigester developed in our laboratory is an Upflow Anaerobic Sludge Blanket (UASB) biodigester that contains a serpentine in which the heated water from the solar collector circulates. Thus, the heat released through the serpentine is used to warm the environment inside the biodigester and to produce the bio gas.

For methane production, the UASB was constructed using stainless steel with 1-m³ working volume. In the literature, many methods were used to heat biodigesters, either by water jacket [4], magnetic agitator; however, in



our case using a serpentine inside the reactor seemed more appropriate since heat is transferred through water from the solar collector.

B. Methane Sensor

Climate change and environment protection developed more domains than just producing energy, and environmental monitoring has its importance as well in reducing GHG emissions. For instance, measuring metrological and hydrological parameters such as temperature [7], light, wind

speed, humidity [8], or even gas emission [6], using wireless sensors mainly discussed in the literature [8]. There is plenty of gas sensing techniques available for proper methane quantity monitoring and control [8], [9].

The volume of methane produced during this digestion process can be measured using a Boyle-Marriott type tank connected to the reactor. However, using new measurement approach is helpful to assure a better result[10].

In this study, we choose to use an MQ-2 gas sensor able to connect with microcontrollers based systems, and this sensor has a response time less than or equal to 10 seconds with wide detection range and also a fast response, high sensitivity, and consumes approximately 180 mA.

The equation implemented on the Arduino board is deduced from the graph of function given in the sensors datasheet by the instructor (Fig. 1). This detector is suitable for detecting LPG, i-butane, propane, methane, alcohol, hydrogen, and smoke. In Fig. 1 Characteristics of parameters sensed by the MQ-2 sensor short, this sensor makes it possible to evaluate the presence of hydrocarbon vapor (the more vapor there is, more the risk of explosion is high).

A. Developed System

The system developed contains a MQ-2 gas sensor, an Arduino board, and a buzzer to warn the instructor in case of excess or deficit in the desired values of the methane quantity. Fig. 2 gives a detailed idea on the entire system.

The sensor will send the methane values to the Arduino board, the latter sends the data to the computer via RS232 cable to visualize and record the variations using a programming code designed with processing.

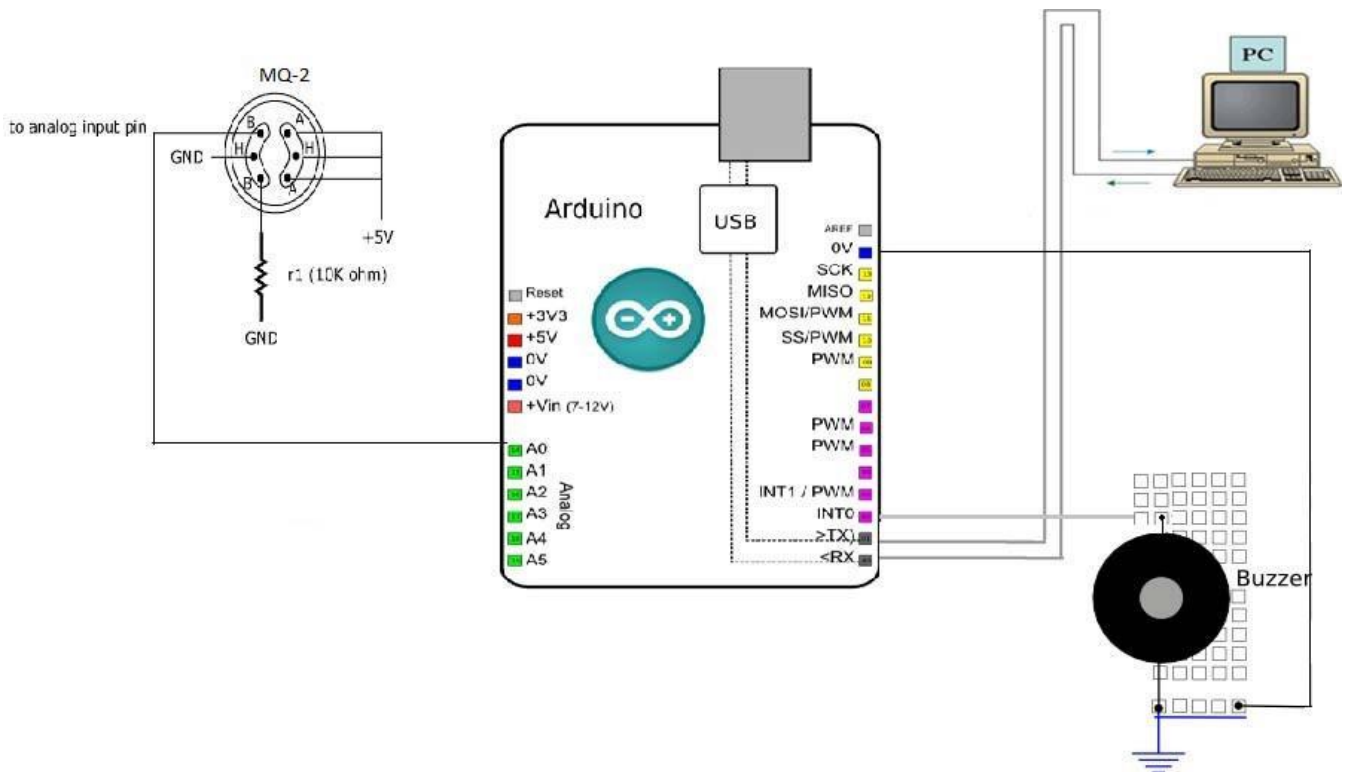
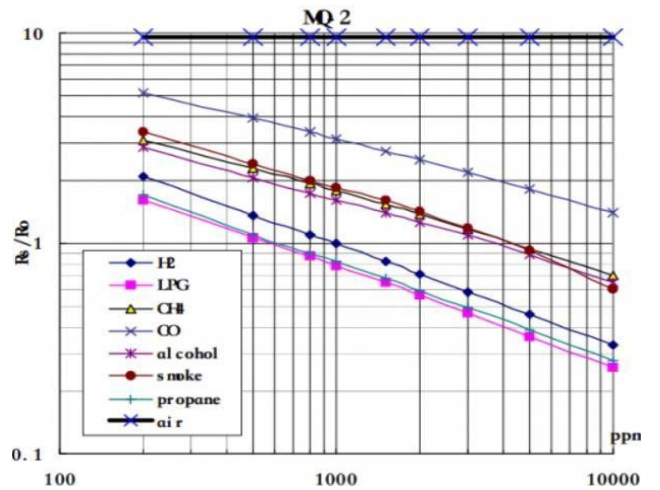

Fig. 2 Main parts of the developed system using Arduino

The codes implemented on the Arduino follow the flowing chart (Fig. 3).

Processing and Arduino use practically the same programming language, and manipulating them is quite

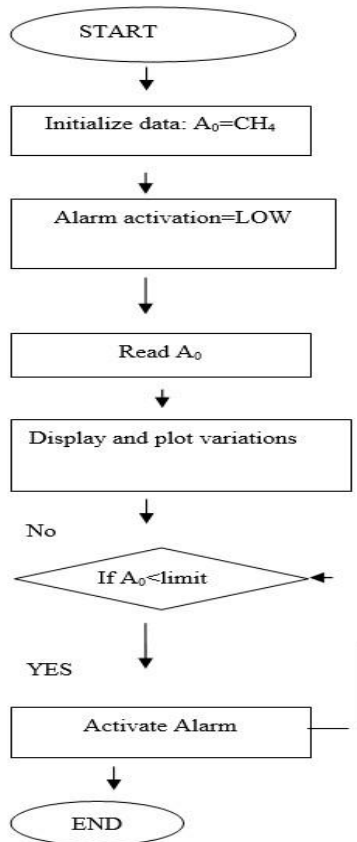

Fig. 3 Steps of the code algorithm implemented on Arduino There are several ways to display the results on the

easy. Processing software also helped us recording the extracted data and creates archives helpful in case of later need.

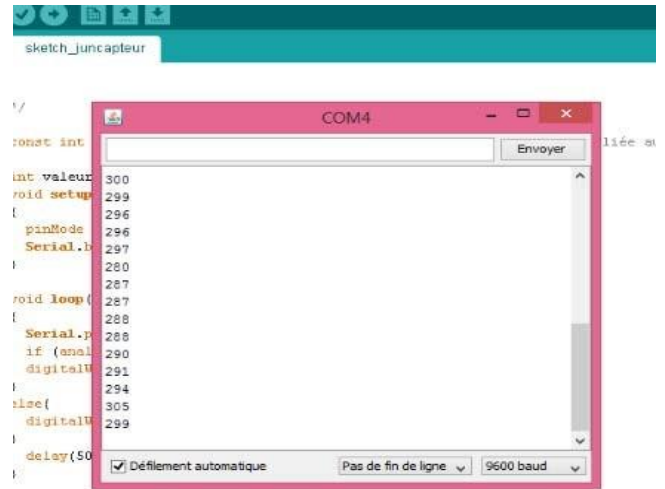

Fig. 4 Values display through Arduino serial monitor transfer

III. RESULTS AND DISCUSSION

As mentioned before, developing such systems consists in bringing the evolution of the technology in the biogas production domain. The evolution of technology cannot be ignored today especially if one is in the field of industry. Realizing an embedded system will allow measuring the quantity of CH₄ produced at the output of the digester at any time and will also record the measured values for future use

[10]-[12].

We should know that the values obtained are in ppm unit (part per million). A ppm corresponds to a ratio of 10⁻⁶, for example one milligram per kilogram. In general, for gases and particles, ppm means 1 ml per m³.

First, with the serial monitor of the Arduino software, the results are given by Fig. 4.



Fig. 5 Methane variation graph using processing software

A graphical result can be displayed using the processing software. The graphical interface is accompanied by a noted. The data are transmitted in real time and displayed immediately on the graph. We also created a data saving file in order to have an archive on the production (Figs. 5 and 6). Thus, using this file, one can consult the register of measurements made. In addition, the text file does not take up much space on the hard drive because it is very light.

The hardware system is realized using different components present in the laboratory, and the Arduino is connected to the computer with a USB cable (Fig. 6).

The system can be used in several methane production furnaces, it is affordable (Table I), simple to realize, and robust at the same time.

TABLE I
COMPONENTS PRICE

Component	Price
Arduino Uno MQ-2	15,50€
Bread Board	20,80€
LED	2,80€
	0,62€

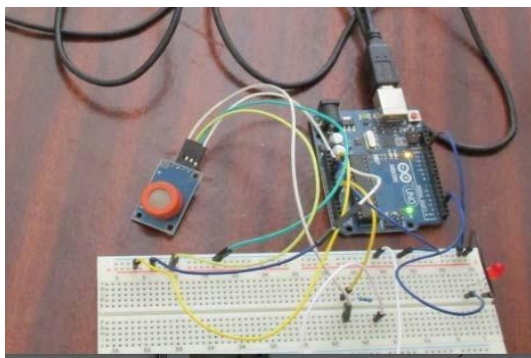

Fig. 6 Hardware implementation in real time simulation

IV. CONCLUSION

The development of biomass exploitation contributes in fighting against global warming since the CO₂ released by the combustion of bio energy is compensated by the CO₂ absorbed by the plants during their growth.

The production of biogas does not require many expenses, therefore its extension is a great asset for the development of each household, but from the industrial point of view, specifically large-scale productions, automating certain stages of production is a necessity in order to save time and also to avoid many labor expenses.

We have been able to achieve the goal of assuring the proper function of the biogas production monitoring and control system; however, it should be noted that, within the framework of our fruition, improvements are still needed; displaying the quantity of methane alone is not sufficient to characterize the quality of the biogas produced, but CO₂ is still essential for the standard to be reached.

REFERENCES

- [1] T. Aboumhaboub, K. Schaber, U. Wagner, and T. Hamacher, "On the CO₂ emissions of the global electricity supply sector and the influence of renewable power-modeling and optimization," *Energy Policy*, vol. 42, pp. 297–314, 2012.
- [2] T. Kousksou *et al.*, "Renewable energy potential and national policy directions for sustainable development in Morocco," *Renew. Sustain. Energy Rev.*, vol. 47, pp. 46–57, 2015.
- [3] D. Hemalatha, S. Sanchitha, and S. Keerthinarayana, "Anaerobic Treatment of Pulp and Paper Mill Wastewater Using Hybrid Upflow Anaerobic Sludge Blanket Reactor (HUASBR)," vol. 3, no. 4, pp. 11576–11584, 2014.
- [4] P. Intanoo, P. Chaimongkol, and S. Chavadej, "ScienceDirect Hydrogen and methane production from cassava wastewater using two-stage upflow anaerobic sludge blanket reactors (UASB) with an emphasis on maximum hydrogen production," *Int. J. Hydrogen Energy*, pp. 1–8, 2015.
- [5] Y. Chen *et al.*, "Mathematical modeling of up flow anaerobic sludge blanket (UASB) reactors: Simultaneous accounting for hydrodynamics and bio-dynamics," *Chem. Eng. Sci.*, vol. 137, pp. 677–684, 2015.
- [6] S. Abdulla, T. L. Mathew, and B. Pullithadathil, "Highly sensitive, room temperature gas sensor based on polyaniline-multiwalled carbon nanotubes (PANI/MWCNTs) nanocomposite for trace-level ammonia detection," *Sensors Actuators, B Chem.*, vol. 221, pp. 1523–1534, 2015.
- [7] A. E. Gürel and İ. Ceylan, "Thermodynamic analysis of PID temperature controlled heat pump system," *Case Stud. Therm. Eng.*, vol. 2, pp. 42–49, 2014.
- [8] M. Wu, L. Tan, and N. Xiong, "Data prediction, compression, and recovery in clustered wireless sensor networks for environmental monitoring applications," *Inf. Sci. (Nij.)*, vol. 329, pp. 800–818, 2016.
- [9] H. E. Gad and H. E. Gad, "Development of a new temperature data acquisition system for solar energy applications," *Renew. Energy*, vol. 74, pp. 337–343, 2015.
- [10] A. B. V. C. Hass, *Operator Training Simulator for Anaerobic Digestion Processes*, vol. 43, no. 6. IFAC, 2012.
- [11] E. M. Ekstrand *et al.*, "Methane potentials of the Swedish pulp and paper industry - A screening of wastewater effluents," *Appl. Energy*, vol. 112, pp. 507–517, 2013.
- [12] J. Isaksson, D. Nilsson, P. Kjäll, N. D. Robinson, A. Richter-Dahlfors, and M. Berggren, "Electronically controlled pH gradients and proton oscillations," *Org. Electron. physics, Mater. Appl.*, vol. 9, no. 3, pp. 303–309, 2008.