

# Advances in Control Strategies for Renewable Energy Systems: A Passivity-Based Approach

Juan Carlos Velásquez-Castro, Santiago Hernández-Tapia, Carlos Eduardo Gómez-Ruiz

1. Electrical Engineering Department, University of Cartagena. Km 3 Vía a Turbaco. A.A. 122. Código postal 130104. Cartagena, Colombia

**ABSTRACT:** This paper presents a Passivity Based Control (PBC) for a dc microgrid. PBC is commonly used in electrical systems such as power electronics converters and electric machines, but there are few applications in microgrids operating in island mode. PBC is based on properties of passive systems and energy exchange between subsystems. The proposed strategy performs primary and secondary control of the hierarchical architecture. Local communications and measurements are needed at the nodes where dc/dc converters are placed. Simulation

High penetration of distributed generation (DG) on power systems is the result of the exploitation of renewable resources (solar and wind) and other alternative forms of energy generation [1]. DG causes impacts at electrical network such as voltage variations and power unbalances [2], which pose new control challenges. To study these problems, the electrical network is divided into smaller units called microgrids (MG), a concept introduced for the first time in [3].

or grid-connected mode in a coordinated way to supply electricity reliably [4].

MG can be generalized into two types: AC and DC. DC microgrids (DC-MG) are a promising technology for integration of electric vehicles, batteries and photovoltaic solar energy [5]. They have intrinsic advantages in terms of efficiency and controllability compared to the more conventional AC microgrids. This is because a DC-MG A DC-MG consists of renewable energy sources, loads and storage units connected to a dc bus as depicted in Figure 1. This type of microgrid can operate in grid-connected mode [7] as well as in island mode [8]. In the former case, it is required an ac/dc converter that fixes the voltage in a *master-slave* operation. In the last case, the control of the DC-MG must

studies are performed in MATLAB to validate the control in a realistic test system composed of renewable energies sources, loads and energy storage units. Results show that the proposed control ensures stability and fast response of the dc-bus voltage under different operating conditions.

**RESUMEN:** Este artículo presenta un Control Basado en Pasividad (CBP) de una microrred DC. El CBP se utiliza comunmente en sistemas eléctricos como convertidores electrónicos de potencia y máquinas eléctricas, pero hay pocas aplicaciones en microrredes que operan en forma aislada. El CBP se fundamenta en las propiedades de los sistemas pasivos y en el intercambio de energía entre subsistemas. La estrategia propuesta desarrolla control primario y secundario de la arquitectura de control jerárquico. Son necesarias comunicaciones locales y mediciones en los nodos donde se ubican convertidores dc/dc. Estudios de simulación son realizados en MATLAB para validar el control en un sistema de prueba real compuesto por fuentes de energía renovables, cargas y unidades de almacenamiento de energía. Los resultados muestran que el control propuesto garantiza estabilidad y rápida respuesta del voltaje del bus dc bajo diferentes condiciones de operación.

be coordinated in a hierarchical architecture that maintains the voltage under a limited range [9].

In general, there are three stages in this architecture namely: primary, secondary and tertiary control. The primary control brings the system to a stable operation using a droop control strategy, while the secondary control ensures system reaches the reference voltage, and the tertiary control defines the reference considering economic, and/or environmental objectives [9]. Primary control is usually local while secondary/tertiary can be designed taking into account communications among the converters.

This paper proposes a Passivity Based Control (PBC) for primary and secondary control of DC-MGs. Compared to conventional approaches, it has the following advantages:

- i) It unifies primary and secondary control in a single stage
- ii) It presents simple mathematical calculation
- iii) It guarantees stability considering the non-linear model of the grid.

The paper is organized as follows: section 2 presents a brief state-of-the-art about DC-MG and PBC. Next, section 3 gives the mathematical model of the grid and the control



requirements. After that, the proposed PBC is described and test DC-MG is presented in section 4. Results are shown in section 5 followed by conclusions in section 6.

# 1. Brief review of the state-of-the-art

## 1.1 DC microgrids

The most common operation mode of DC-MG is the master-slave control. In this strategy, the main AC/DC converter imposes the voltage of the system and the other terminals work in maximum power point tracking at constant power or constant current [10]. This type of control is simple and guarantees stability but depends on the capability of the master terminal to maintain a constant voltage. DC-MG can separate from the main grid when a power quality disturbance occurs. In case of lost of this terminal, the DC-MG must change the operation in order to maintain stable operation. A hierarchical primary/secondary/tertiary control is used in this case to control the transition. The main dc/dc converter is master terminal and DC-MG operates in island mode. The new master controls dc-bus voltage and power flow. The surplus or deficient power must be compensated by

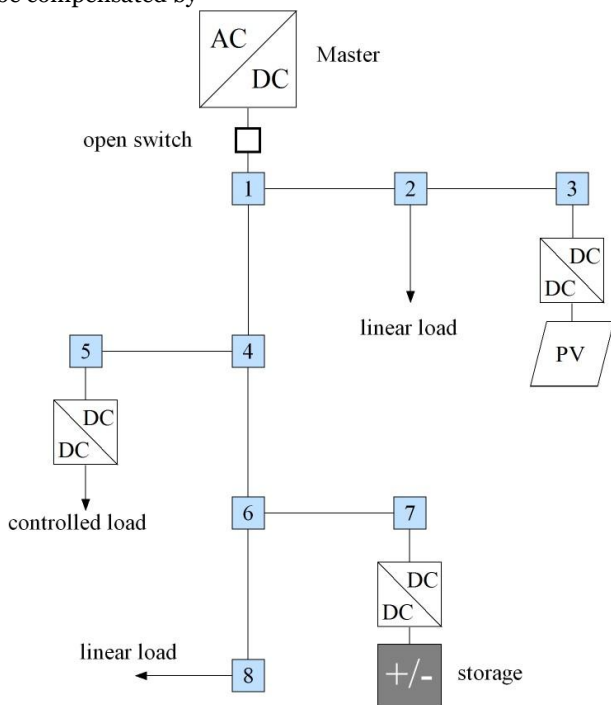

Figure 1 Example of a DC-MG under island operation

the other elements of the network. Then, changes in the element operation are required to DC-MG stabilization. It is a cooperative control where generations, loads and energy

storage units are involved. Thus, communications are necessary.

Master-slave control can be considered from the communication perspective as a centralized control. This category features by data collection from the distributed units in the master terminal to define a overall control strategy [11]. Tertiary level performs this action by means of a properly managing the energy balance in the system. Primary and secondary levels in hierarchical architecture, can be local controls as shown in Figure 2, but they need communications with upper level.

## 1.2 Passivity based control

There are many applications in the literature about PBC in mechanical, electrical and electromechanical systems [12]. In electricity, the two historical topics have been electrical machines and power electronics converters, specially switched power converter with constant power loads in dc/dc [13–15], nonlinear loads [16], dc/ac converter [17] and Pasivity based PI controls [18] among others. Hybrid energy control [19–22] and PBC-fuzzy logic are studied in [23] and [24]. An automotive power systems application is a PBC of a vehicular microgrid [25]. In HVDC transmission systems, passivity concept is used in modular multilevel converter control [26, 27].

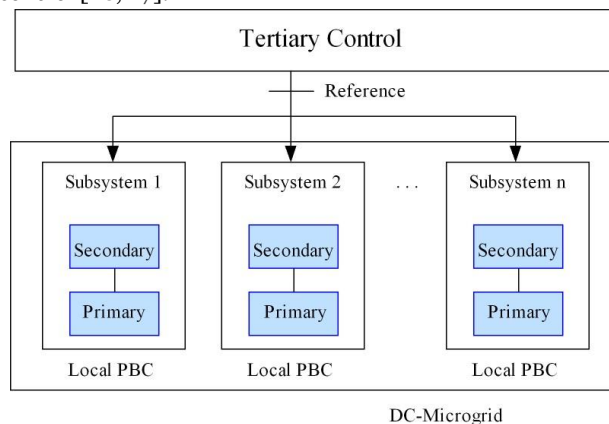

Figure 2 Control structure

The problem of DC-MG stabilization is considered in few publications, where PBC is used to ensure stability of classical controls. Different stabilization strategies for DC-MG are discussed in [28], to prevent undesired effects produced by constant power loads. In that work, passivity concept is used in a PD controller. In [29], PBC theory is also used in system passivisation shaping the admittance through voltage feed forward as a modification of the classical PID.

## 2. Modeling and control of DC-microgrids

### 2.1 Modeling of DC-microgrids

The DC-MG modeling takes into account each of its elements. In the literature, different models are found depending on the control objective. Generators and storage units are commonly modeled as voltage or current sources [30–33]. Another option is voltage sources with series resistances [32, 34] and current sources with parallel resistances [34].

Loads through resistors [34], RL networks [35], current sources [30, 32], current sources with parallel resistances [34] and constant power blocks [36]. The connection lines between DC buses are modeled using resistors [32, 37, 38], RL [36, 39] and RLC models [31, 40].

In the converters, RLC networks are used to operate as a filter and they serve as a coupling element with the connection lines [30, 34]. In some cases, the capacitor is associated with the power converter and the impedance RL with connection line between converter and DC bus [41]. In other cases, the capacitor is located on the side of the DC bus [42]. The control action acts on the converters, so they are modeled in some cases as dependent sources [31].

### 2.2 Proposed model of the grid

A DC-MG is composed of a set buses  $N$  and lines  $E \subseteq N \times N$  which connect these buses. The grid in island mode can be either radial or meshed but its graph must be connected (i.e. there are not sub-islands).

Any distributed resource such as a photovoltaic panel, a wind turbine, an energy storage device or an electric vehicle, is integrated to the grid through a dc/dc converter. These devices maintain a constant power and introduce a non-linearity which must be considered in the design of the control. Other equipments allow a constant resistance model. Therefore, each bus is represented as a constant power terminal in parallel with a capacitor and a constant admittance as shown in Figure 3. The capacitor represents capacitance of the cable plus the capacitance of the converter.

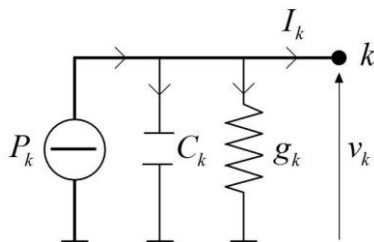

Figure 3 Model of each terminal in the proposed DC-MG

In the analysis, it is desirable to reduce the network by eliminating the nodes in which the current do not enter or leave. This procedure is known as Kron’s Elimination [43, 44].  $N$  can be represented in two subsets:  $N = \{R, P\}$ ,  $R$  are nodes to eliminate and  $P$  contains nodes where current is injected. In Figure 1, subset  $P = \{3, 5, 7\}$  defines the equivalent DC-MG, which is shown in Figure 4. It can be noted that equivalent DC-MG has only nodes in which there are connected dc/dc converters.

$P$  nodes form the resulting admittance matrix. Bus admittance matrix is partitioned with matrices  $K, L$  and  $M$  as defined in (1).

$$\begin{bmatrix} I_R \\ I_P \end{bmatrix} = \begin{bmatrix} K & L^T \\ L & M \end{bmatrix} \begin{bmatrix} V_R \\ V_P \end{bmatrix} \tag{1}$$

Matrix formulation can be written as (2) and (3).

$$I_R = KV_R + L^T V_P \tag{2}$$

$$I_P = LV_R + MV_P \tag{3}$$

If  $I_R = 0$  then  $V_R = -K^{-1}L^T V_P$ . Rewritten (3) gives

(4), where it is obtained the reduced bus admittance matrix

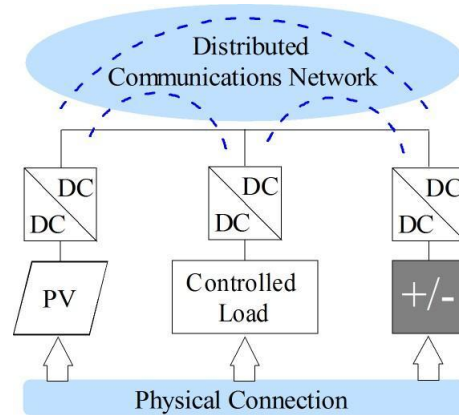

Figure 4 Equivalent DC-MG

which is given in (5).

$$I_P = (M - LK^{-1}L^T)V_P \tag{4}$$

$$G = M - LK^{-1}L^T \tag{5}$$

$G$  is the nodal admittance matrix which includes the admittances of the terminals ( $g_k$ ) as well as the admittances of the lines ( $1/r_{km}$ ). Figure 5 shows the model of each node  $P$  in network equivalent.

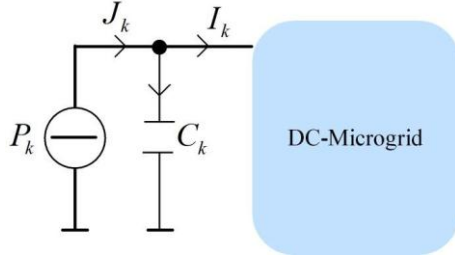

**Figure 5** Model of each  $P$  node in equivalent DC-MG

$G$  has implicitly the interconnection information of the nodes  $P$  in the microgrid. Dynamics of each node is given by (6).

$$J_k = \frac{P_k}{V_k} = C_k \frac{dV_k}{dt} + I_k \quad (6)$$

From the previous equation, the system model is obtained as indicated in (7).

$$\frac{dV_k}{dt} = C_k^{-1} \left( \frac{P_k}{V_k} - I_k \right) \quad (7)$$

But  $I$  can be expressed in terms of  $G$  using equation  $I = GV$ . This allows a matrix representation as defined in (8),

$$\frac{dV}{dt} = C^{-1} \left( [\text{diag}(V^{-1})]P - GV \right) \quad (8)$$

where  $V$  are the state variables,  $C$  is the capacitance matrix,  $G$  is reduced bus admittance matrix and  $P$  is a vector with the value of the controlled power in each dc/dc converter.

Defining  $V = X$  and  $P = u$  in (8) and simplifying yields (9).

$$\frac{dX}{dt} = C^{-1} \left( [\text{diag}(X^{-1})]u - GX \right) \quad (9)$$

This model is general for any dc microgrid with the aforementioned characteristics. Notice, this is a non-linear system which requires a coordinated control.

## 2.3 Control requirements

Conventional operation of MG in island mode is based in a hierarchical primary/secondary/tertiary control. Primary control is distributed and operates without communications. It guarantees stability of the grid after the master converter is disconnected. The secondary control brings the system to a desired operative point. This can be done with or without communications. Finally, a tertiary control determines the optimal operative point according economical or environmental objectives. It is usually centralized or distributed with communications.

Primary and secondary controls can be unified in a single control with the following requirements: a) it must

guarantee stability of the system and b) it must bring the system to the expected operative point.

## 3. Passivity based control

Energy-based modeling has been used mainly in classical mechanical systems. Euler-Lagrange and Hamiltonian representations describe energy and interconnection properties in physical systems [45]. These properties can be exploited in feedback controllers. Passivity concept allows the control systems to be analyzed as energy exchange units. It is based on energy function and dissipation structure of the systems. PBC reshapes energy of system in closed loop and forces system response a desired values [46].

### 3.1 Passive system

A system is passive if there exists a scalar function  $H(x)$  bounded from below, and a nonnegative function  $d(t) \geq 0$  which satisfies (10)

$$\int_0^t u^T(s)y(s)ds = H(x(t)) - H(x(0)) + d(t) \quad (10)$$

where  $\int_0^t u^T(s)y(s)ds$  is the energy supplied to the system,  $H(x(t)) - H(x(0))$  is stored and  $d(t)$  is dissipated energy. If  $H(x_0)$  is a global minimum of  $H(x)$ ,  $d(t) \geq 0$  and  $u = 0$ ,  $H(x(t))$  will decrease in time and the system will reach  $x_0$  asymptotically.  $x_0$  is a natural equilibrium point.

There are many types of systems which fulfill this definition. We are interested in Hamiltonian system which have the form expressed in (11):

$$\frac{dX}{dt} = (J - R) \frac{\partial H}{\partial x} \quad (11)$$

where  $x \in R^n$ ,  $H : R^n \rightarrow R$  is the total stored energy,  $J = -J^T$  and  $R = R^T \geq 0$  are the interconnection and damping matrices. *Property:* If  $H \geq 0$  and  $H(x_0)$  is minimum, then  $\dot{H} \leq 0$ . Hence,  $H$  qualifies as a Lyapunov function. These conditions guarantee stability [47].

An important property of passivity is the interconnection of passive systems, which yields a passive system [48]. This property is useful for microgrids where interconnection between plants and controllers exchange energy over a network. A controller must enforce the plant to change the equilibrium point to a desired value.

### 3.2 PBC for DC-MG

In this case,  $H$  is defined by (12):

$$H = \frac{1}{2}(X - X_o)^T(X - X_o) \tag{12}$$

where  $X_o$  is the reference voltages.  $\frac{\partial H}{\partial x}$  for proposed  $H$

is shown in (13)

$$\frac{\partial H}{\partial x} = X - X_o \tag{13}$$

Defining null the interconnection matrix ( $J = 0$ ) and using (13), the Hamiltonian system expressed in (11) can be rewritten as (14)

$$\frac{dX}{dt} = -R(X - X_o) \tag{14}$$

If it is defined the damping matrix as  $R = \mu C^{-1}G$  where  $\mu$  is a positive scalar associated to the speed of convergence, it is true that  $R \succcurlyeq 0$ . Then (14) is expressed as (15)

$$\frac{dX}{dt} = -\mu C^{-1}G(X - X_o) \tag{15}$$

equating (9) and (15) is found the resulting control law which is given in (16).

$$u = \text{diag}(X)(GX - \mu G(X - X_o)) \tag{16}$$

This result is a matrix formulation whose size depends on the  $P$  nodes (control nodes), as indicated in the Kron's Elimination section. It is only possible to perform control actions at nodes where power converters are connected. In the DC-MG of Figure 1, the control nodes are 3, 5 and 7. The matrix formulation allows using the control law to any test model even complex models.

From (16), retaking the original variables ( $X = V$  and  $u = P$ ) and defining  $n$  as the number of converters that operate in island mode, it can be obtained the control signal for  $k$  node as defined in (17).

$$u_k = V_k \left( \sum_{m=1}^n G_{km} V_m - \mu \sum_{m=1}^n G_{km} (V_m - V_o) \right) \tag{17}$$

To evaluate the control law, it is necessary to know the admittances and the voltage in the converters. This control can be implemented in a distributed form. Only voltage of dc/dc converters are required since the valued of  $G_{km}$  are already known. This information can be exchanged by communications as depicted in Figure 4.

### 3.3 Test model

The proposed control strategy is verified by simulation. The DC-MG is depicted in Figure 1 which is composed of sources, loads and energy storage devices. The system includes a 2kW photovoltaic solar generation and an energy storage unit of 48V dc-bus voltage. Loads are described in Table 1. The DC-MG has capacity to store the energy produced and supply loads in island mode. There are two line types: terminal lines for connection loads and connection lines to link sources with energy storage. Parameters of lines, cables and network elements are given in Tables 2, 3 and 4.

**Table 1** Load rated values

Node	Description	Power
2	Constant power terminal	500W
8	Constant power terminal	800W
5	Controlled load	Pmax. 1200W

**Table 2** Line parameters

Type	Size	
	AWG	Area[mm <sup>2</sup> ]
Line connection	8	8.37
Line terminal	12	3.31

**Table 3** Cables parameters

AWG	Current rating [A]	Resistance [ $\Omega$ /km]
8	50	2.1
12	25	5.2

**Table 4** Network components description

Node From	Node To	Resistance [ $\Omega$ /km]	Length [m]
1	2	2.1	10
2	3	2.1	25
1	4	2.1	5
4	5	5.21	22
4	6	2.1	8
6	7	2.1	20
6	8	5.21	16

## 4. Results

As mentioned above, a PBC performs the primary and secondary control actions of the hierarchical control levels. The tertiary control defines the reference, which is the input of the PBC proposed. Initially the grid supplies 1300W to DC-MG and the battery is charging. Then, DC-MG is disconnected and the battery must supply missing energy. This is a starting point for simulation. There are two case studies. First, it occurs in the period  $t < 10s$ , where DC-MG is stabilized after grid disconnection. In  $t = 10s$ , controlled load increases in 100W. The second case corresponds to period  $t > 10s$ , which DC-MG stabilizes again for new load conditions. State variables are voltages in nodes 3, 5 and 7. In node 3, there is a source that supplies constant power. In

node 5 is the controlled load and node 7 is the energy storage system. Power values in  $W$  are included in Table 6. Simulation results show voltages, currents and powers related to interest nodes as seen in Figure 6, Figure 7 and Figure 8. It can be observed that changes in load are compensated by energy storage unit. In the case studies, DC-MG reaches a new stable operation point with damping behavior. A summary of the values of voltage in  $V$  and current in  $A$  of steady state obtained are given in Table 7 and Table 5.

The above results were obtained by defining  $\mu$  equal to 2. As mentioned,  $\mu$  is a positive scalar associated to the speed of convergence. In Figure 9, current results at Node 7 are included for different  $\mu$  values. Notice  $\mu$  does not compromise stability, only the response time.

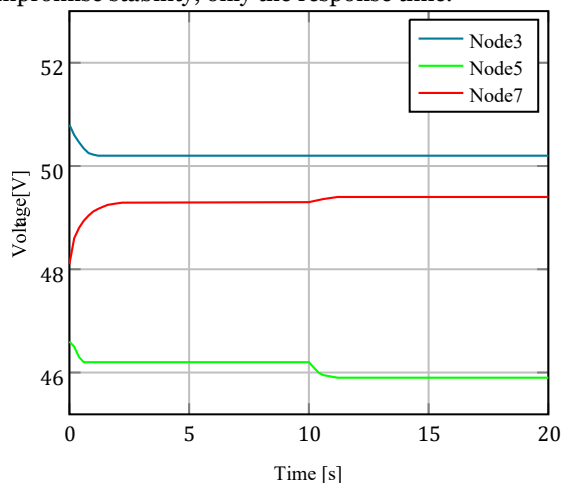

Figure 6 Voltages in DC-MG

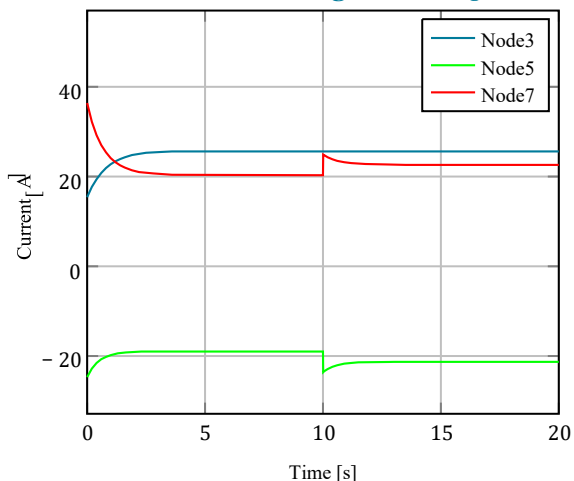

Figure 7 Currents in DC-MG

## 5. Conclusions

This paper proposed a PBC for DC-MG stabilization. The exposed properties demonstrated asymptotic stability of the controller. A Hamiltonian structure was used to obtain a desired energy function in closed-loop. The proposed control strategy presented simple mathematical calculation and allowed primary and secondary control. A test DC-MG used was built in MATLAB to evaluate the dynamic performance of the controller. Simulation results shown dc-voltage regulation was achieved with good stability and damping properties.

Time [s]

	Node	
	$t < 10s$	$t > 10s$
3	25.6	25.6
5	-19.0	-21.3
7	20.3	22.6

Table 6 Active power in the cases studies

	Initial condition	Case studie	
		$t < 10s$	$t > 10s$
3	1285	1285	1285
5	-880	-880	-980
7	-300	1000	1120

Node

Table 7 Voltages in the cases studies

	Initial condition	Case studie	
		$t < 10s$	$t > 10s$
3	50.8	50.2	50.2
5	46.6	46.2	45.9
7	48.1	49.3	49.4

Node

## 6. References

- [1] C. Bordons, F. García, and L. Valverde, "Gestión óptima de la energía en microrredes con generación renovable," *Revista Iberoamericana de Automática e Informática Industrial RIAI*, vol. 12, no. 2, pp. 117-132, 2015.
- [2] P. P. Barker and R. W. De Mello, "Determining the impact of distributed generation on power systems: Part 1-radial distribution systems," in *Power Engineering Society Summer Meeting*, Seattle, USA, 2000, pp. 1645-1656.
- [3] R. H. Lasseter, "Microgrids," in *Power Engineering Society Winter Meeting*, New York, USA, 2002, pp. 305-308.
- [4] D. E. Olivares *et al.*, "Trends in microgrid control," *IEEE Transactions on smart grid*, vol. 5, no. 4, pp. 1905-1919, 2014.
- [5] T. Dragicevic, J. C. Vasquez, J. M. Guerrero, and D. Skrllec, "Advanced LVDC electrical power architectures and microgrids: A

- step toward a new generation of power distribution networks," *IEEE Electrification Magazine*, vol. 2, no. 1, pp. 54-65, 2014.
- [6] D. Chen and L. Xu, "DC microgrid with variable generations and energy storage," in *IET Conference on Renewable Power Generation (RPG 2011)*, Edinburgh, UK, 2011, pp. 1-6.
- [7] K. Kurohane *et al.*, "A distributed dc power system in an isolated island," in *IEEE International Symposium on Industrial Electronics*, Seoul, South Korea, 2009, pp. 1-6.
- [8] H. Kakigano, Y. Miura, T. Ise, and R. Uchida, "Dc micro-grid for super high quality distributionsystem configuration and control of distributed generations and energy storage devices," in *37<sup>th</sup> IEEE Power Electronics Specialists Conference*, 2006, pp.1-7.
- [9] Z. H. Jian, Z. Y. He, J. Jia, and Y. Xie, "A review of control strategies for DC micro-grid," in *Fourth International Conference on Intelligent Control and Information Processing (ICICIP)*, Beijing, China, 2013, pp. 666-671.
- [10] D. Boroyevich, "Future electronic power distribution systems a contemplative view," in *12<sup>th</sup> International Conference on Optimization of Electrical and Electronic Equipment*, Brasov, Romania, 2010, pp. 1369-1380.
- [11] T. Dragičević, X. Lu, J. C. Vásquez, and J. M. Guerrero, "Dc microgrids-Part I: A review of control strategies and stabilization techniques," *IEEE Transactions on power electronics*, vol. 31, no. 7, pp. 4876-4891, 2016.
- [12] R. Ortega and E. García, "Interconnection and Damping Assignment Passivity-Based Control: A Survey," *European Journal of Control*, vol. 10, no. 5, pp. 432-450, 2004.
- [13] Kwasinski and P. T. Krein, "Passivity-Based Control of Buck Converters with Constant-Power Loads," in *IEEE Power Electronics Specialists Conference*, Orlando, USA, 2007, pp. 259-265.
- [14] A. Kwasinski and P. T. Krein, "Stabilization of constant power loads in DC-DC converters using passivity-based control," in *INEC 07 - 29<sup>th</sup> International Telecommunications Energy Conferenc*, Rome, Italy, 2007, pp. 867-874.
- [15] J. Zeng, Z. Zhang, and W. Qiao, "An Interconnection and Damping Assignment Passivity-Based Controller for a DCDC Boost ConverterWith a Constant Power Load," *IEEE Transactions on Industry Applications*, vol. 50, no. 4, pp. 2314-2322, 2014.
- [16] E. Lenz, D. J. Pagano, and V. Stramosk, "Nonlinear control applied to a dc-dc power converter and the load sharing problem in a dc microgrid," *IFAC Proceedings Volumes*, vol. 47, no. 3, pp. 534-539, 2014.
- [17] K. Mu, X. Ma, X. Mu, and D. Zhu, "Study on passivity-based control of voltage source PWMDC/AC inverter," in *International Conference on Electronic and Mechanical Engineering and Information Technology*, Harbin, China, 2011, pp. 3963-3967.
- [18] M. Perez, R. Ortega, and J. R. Espinoza, "Passivity-based PI control of switched power converters," *IEEE Transactions on Control Systems*, vol. 12, no. 6, pp. 881-890, 2004.
- [19] M. Y. Ayad, M. Becherif, D. Paire, A. Djerdir, and A. Miraoui, "Passivity-Based Control of Hybrid Power Sources using Fuel Cell, Supercapacitors, and Batteries on the DC link for Energy Traction System," in *IEEE International Electric Machines Drives Conference*, Antalya, Turkey, 2007, pp. 453-458.
- [20] S. Mane, F. Kazi, and N. M. Singh, "Fuel cell and ultra-capacitor based hybrid energy control using IDA-PBC methodology," in *International Conference on Industrial Instrumentation and Control (IICIC)*, Pune, India, 2015, pp. 879-884.
- [21] S. M. Mane *et al.*, "Passivity Based Control of Complex Switched Mode FC-UC Hybrid Structure with BM Modeling," *IFAC-PapersOnLine*, vol. 48, no. 30, pp. 345-350, 2015.
- [22] A. Tofighi and M. Kalantar, "Passivity-based control of PEM fuel cell/battery hybrid power source," in *IEEE Energy Conversion Congress and Exposition*, Phoenix, USA, 2011, pp. 902-908.
- [23] M. Mohammadi *et al.*, "Fuzzy logic and passivity based control applied to hybrid DC power source using fuel cell and battery," in *4<sup>th</sup> International Conference on Systems and Control (ICSC)*, Sousse, Tunisia, 2015, pp. 510-515.
- [24] M. Mohammadi *et al.*, "Passivity Based Control and Fuzzy Logic Estimation applied to DC hybrid power source using Fuel Cell and supercapacitor," in *3<sup>rd</sup> International Conference on Systems and Control*, Algiers, Algeria, 2013, pp. 77-82.
- [25] M. Srinivasan and A. Kwasinski, "Decentralized control of a vehicular microgrid with constant power loads," in *IEEE International Electric Vehicle Conference (IEVC)*, Florence, Italy, 2014, pp. 1-8.
- [26] X. Cai, C. Zhao, T. Li, and L. Li, "Passivity-based control of HVDC transmission system based on modular multilevel converter under unbalanced grid conditions," in *2<sup>nd</sup> IET Renewable Power Generation Conference (RPG)*, Beijing, China, 2013, pp. 1-4.
- [27] A. Jaafar, G. Bergna, J. C. Vannier, and P. Lefranc, "Energy concept-based nonlinear stabilization and control for Modular Multilevel Converters for voltage oscillation reduction," in *16<sup>th</sup> European Conference on Power Electronics and Applications (EPE'14-ECCE Europe)*, Lappeenranta, Finland, 2014, pp. 1-10.
- [28] A. Kwasinski and C. N. Onwuchekwa, "Dynamic Behavior and Stabilization of DC Microgrids With Instantaneous Constant-Power Loads," *IEEE Transactions on Power Electronics*, vol. 26, no. 3, pp. 822-834, 2011.
- [29] Y. Gu, W. Li, and X. He, "Passivity-Based Control of DC Microgrid for Self-Disciplined Stabilization," *IEEE Transactions on Power Systems*, vol. 30, no. 5, pp. 2623-2632, 2015.
- [30] F. Dorfler and F. Bullo, "Kron reduction of graphs with applications to electrical networks," *IEEE Transactions on Circuits and Systems I: Regular Papers*, vol. 60, no. 1, 150-163, 2013.
- [31] A. Chakrabarti and S. Halder, *Power System Analysis: Operation And Control*, 3<sup>rd</sup> ed. New Delhi, India: PHI Learning Pvt. Ltd., 2010.
- [32] R. Ortega, A. Loria, P. J. Nicklasson, and H. Sira, *Passivity-based Control of Euler-Lagrange Systems*. London, United Kingdom: Springer London, 1998.
- [33] R. Ortega and E. Garca, "Interconnection and damping assignment passivity-based control: A survey," *European Journal of control*, vol. 10, no. 5, pp. 432-450, 2004.
- [34] J. C. Willems, "Dissipative dynamical systems part i: General theory," *Archive for Rational Mechanics and Analysis*, vol. 45, no. 5, pp. 321-351, 1972.
- [35] M. Wu and D. D. Lu, "A novel stabilization method of LC input filter with constant power loads without load performance compromise in DC microgrids," *IEEE Transactions on Industrial Electronics*, vol. 62, no. 7, pp. 4552-4562, 2015.
- [36] C. Gavriluta, I. Candela, C. Citro, A. Luna, and P. Rodriguez, "Design considerations for primary control in multi-terminal VSC-HVDC grids," *Electric Power Systems Research*, vol. 122, pp.33-41, 2015.
- [37] K. A. Saleh, A. Hooshyar, and E. F. El, "Hybrid passiveovercurrent relay for detection of faults in low-voltage DC grids," *IEEE Transactions on Smart Grid*, vol. 8, no. 3, 1129-1138, 2017.
- [38] L. Herrera, W. Zhang, and J. Wang, "Stability analysis and controller design of DC microgrids with constant power loads," *IEEE Transactions on Smart Grid*, vol. 8, no. 2, pp. 881-888, 65 2017.
- [39] S Pulido, J. P. Martin, B. Nahid, and S. Pierfederici, "Stabilization of a distributed DC power system by shaping loads input impedance: Feedforward stabilization," in *40<sup>th</sup> Annual Conference of the IEEE Industrial Electronics Society, IECON*, Dallas, USA, 2014, pp. 1820-1826.

- [40] T. Dragicevic, J. M. Guerrero, J. C. Vasquez, and D. Krlec, "Supervisory control of an adaptive-droop regulated DC microgrid with battery management capability," *IEEE Transactions on Power Electronics*, vol. 29, no. 2, pp. 695-706, 2014.
- [41] N. Bottrell, M. Prodanovic, and T. C. Green, "Dynamic stability of a microgrid with an active load," *IEEE Transactions on Power Electronics*, vol. 28, no. 11, pp. 5107-5119, 2013.
- [42] A. Kwasinski and C. N. Onwuchekwa, "Dynamic behavior and stabilization of DC microgrids with instantaneous constant power loads," *IEEE Transactions on Power Electronics*, vol. 26, no. 3, pp. 822-834, 2011.
- [43] J. Beerten and R. Belmans, "Analysis of power sharing and voltage deviations in droop-controlled DC grids," *IEEE Transactions on Power Systems*, vol. 28, no. 4, pp. 4588-4597, 2013.
- [44] M. Hamzeh, A. Ghazanfari, Y. A. Mohamed, and Y. Karimi, "Modeling and design of an oscillatory current-sharing control strategy in DC microgrids," *IEEE Transactions on Industrial Electronics*, vol. 62, no. 11, pp. 6647-6657, 2015.
- [45] A. Maknouninejad, Z. Qu, F. L. Lewis, and A. Davoudi, "Optimal, nonlinear, and distributed designs of droop controls for DC microgrids," *IEEE Transactions on Smart Grid*, vol. 5, no. 5, pp. 2508-2516, 2014.
- [46] V. Nasirian, S. Moayedi, A. Davoudi, and F. L. Lewis, "Distributed cooperative control of DC microgrids," *IEEE Transactions on Power Electronics*, vol. 30, no. 4, pp. 2288-2303, 2015.
- [47] A. Karimi, A. Pirayesh, T. S. Aghdam, and M. Ajalli, "DC microgrid small signal stability analysis," in *18<sup>th</sup> Conference on Electrical Power Distribution Networks (EPDC)*, Kermanshah, Iran, 2013, pp. 1-4.
- [48] K. Rykov, L. Ott, J. L. Duarte, and E. A. Lomonova, "Modelling of aggregated operation of power modules in low-voltage DC grids," in *16<sup>th</sup> European Conference on Power Electronics and Applications (EPE14-ECCE Europe)*, Lappeenranta, Finland, 2014, pp. 1-9.