

Development of an Optoelectronic System for Automatic Smartphone Charging

Ameya Bapat, Kunal Patil, Aryaman Chavan, Yogesh Kulkarni, Dnyaneshwar Kamble

Indian Institute of Technology, Mumbai; Electrical Engineering Department, Amravati University, Amravati; Electronics Research Laboratory, Pune University, Pune

ABSTRACT:

Today's smartphones are very power hungry. They use powerful hardware including multicore CPU, many GPU cores, large screen and high-speed wireless network interfaces, all with a high power consumption. They also run many energy-expensive applications such as high-end games, full HD video playback, and various continuous sensing tasks for context awareness. As a result, many users suffer from a short battery lifetime on their smartphones and thus they often have to recharge their smartphones every day or even multiple times per day. To make user put in less efforts and have a full battery every time they use their smartphone we have researched the idea of AutoCharge. The idea was conceived by Microsoft [1], but their design was a costly affair for the regular consumer. Taking inspiration from Microsoft we have made a prototype which can cater users from all walks of life.

INDEX: Introduction, Literature review, Design components and specification, Block diagram, Results, Applications, Advantages and Disadvantages, Conclusion, Future scope.

I. INTRODUCTION:

The frequent smartphone recharging imposes a big burden to users. As people increasingly depend on their smartphones for daily work and life, running out of battery becomes a very unacceptable situation for many users. To avoid such an unpleasant situation,

users must keep a careful eye on the battery status of their smartphones and manually connect a charger to charge their smartphones when the battery is low. Doing so every day not only consumes a lot of user attentions but also imposes a mental burden to users. , smartphones should automatically get recharged so that users do not need to worry about recharging their smartphones. However, existing solutions cannot achieve this desirable goal. With a wired charger, users must manually plug the charger into a smartphone, to explicitly express their intention of charging. Even with a wireless charging pad (e.g., the one used by Lumia 920 or Nexus 4), users still need to explicitly put a smartphone onto a small charging pad to indicate the intention of charging. That is, users still have to manually connect a charger to their smartphones, resulting in the similar user burden as wired chargers. Therefore, wireless charging pads do not improve the user experience much.

II. LITERATURE REVIEW:

Smartphone charging imposes a big burden to users because they often have to recharge their smartphones every day or even multiple times per day. Smartphones can get automatically charged without requiring explicit effort from users to this end, a new approach, called AutoCharge, to explore the feasibility of automatic smartphone charging. The AutoCharge approach automatically locates a smartphone on a desk and charges it in a transparent manner from the user. This is achieved by two techniques. First, leverage solar charging technique is used but use it in indoor spaces, to remotely charge a smartphone using a light beam without a wire. Secondly, employ an image-processing based technique to detect and track smartphones on a desk for automatic smartphone charging. As a result, AutoCharge is able to largely reduce users' efforts in smartphone charging and significantly improve the user experience. Research is going on design & implementation of a prototype system of the AutoCharge approach. We report the design details of the light charger and the smartphone detection and tracking system are given by Yunxin Liu, Zhen Qin and Chunshui Zhao Microsoft Research in [1][2].

Experimental results show that prototype is able to detect the presence of a smartphone within seconds and charge it as fast as existing wired chargers, demonstrating the feasibility of automatic smartphone



III. DESIGN COMPONENTS AND SPECIFICATION:

This system contain different component with its own specifications for proper operation of system . Some of them are listed below.

1 SYSTEM SPECIFICATION:

•Output: Fully charge a battery of 3300 mAH in 5 hours (assuming a charging voltage of 5 V).

2HARDWARE REQUIREMENT

2.1 Charger side components

•Light Beam charging.

- Camera
- ATmega16 microcontroller
- Bluetooth module
- Relay
- 2.2 Smartphone side components
- Smartphone
- Solar PV panel
- Charging Circuit

SR NO.	COMPONENTS	SPECIFICATION
1	Microcontroller	ATmega16, 40-Pin,32-KBR, Programmable memory, 512byte-EEPROM, 1kbyte SRAM, 32-I/O Line, 5V, 200mA
2	Web cam	12 MP
3	Bluetooth (HC-05)	5V, 50mA, 2.4GHz, Temp: 20° ~ -75C, Speed: 1Mbps, Dimension: 26.9mm*13mm*2.2mm
4	Relay	5V
5	Voltage Regulator	5V
6	Step Down Transformer	Down 9V, 500mA
7	Rectifier	1A
8	Filter Capacitor	1000µf 35V
9	Solar PV Panel	12V
10	LED Light	7W
11	USB serial cable	1 Mbps data transfer rate

3 SOFTWARE REQUIREMENT

- Programming language: MatLab[4] , Android

IV. BLOCK DIAGRAM:

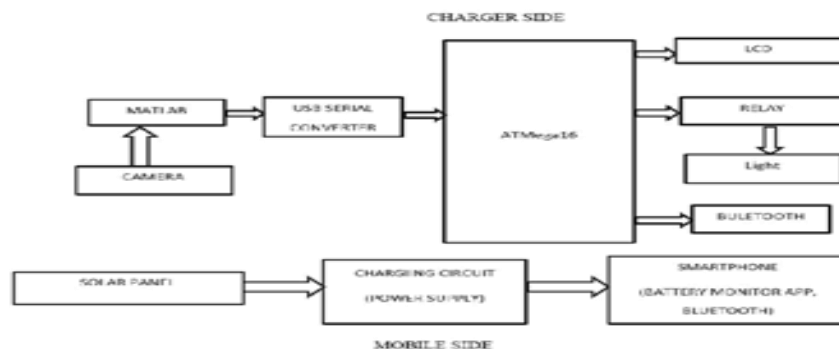

Fig.BlockDiagram



Fig. Project setup in standby mode



Fig. Project setup in running mode

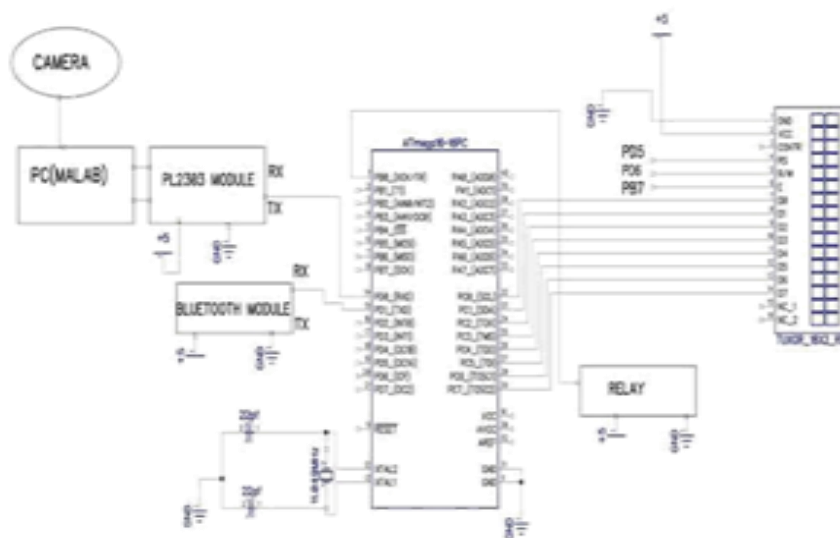

Fig. Circuit Diagram

Figure illustrates how a system of AutoCharge works. The system consists of two parts: a light charger and a smartphone. The light charger has four components: a light which generates a straight light beam; a camera which monitors a surface like a table; a programmable rotator which moves the light and the camera to adjust their direction; and a controller which controls the movement of the rotator and turns on/off the light. The controller also runs necessary software to analysis the images captured from the camera to detect a smartphone. To be charged by the light charger, the smartphone must integrate a solar panel to harvest energy from the light beam of the light charger.

1. LIGHT CHARGER:

The light charger has two components: a light which generates a light beam; a camera which monitors a surface like a table.

2. LIGHT BEAM:

Wireless charging pads may be more convenient than traditional wired smartphone chargers. Pads still require users to consciously place their phone in a specific spot, for the express purpose of charging. Instead, they envision a system in which users just toss their phone onto a table, where it's automatically charged using a beam of light. They've already built a working prototype of the system, which is known as AutoCharge.

The light charger works in two modes: a detection mode and a charging mode. In the detection mode, the light is turned off. The camera is on and continuously monitors. The data of the continuous monitoring is sent to the controller which analyzes the content of the data to decide whether there is a smartphone or not. If a smartphone is detected, the light charge goes to the charging mode.

3. CAMERA:

Using an overhead camera (a Web camera, in the case of the current prototype) and object recognition software (MatLab), AutoCharge continuously scans the table top, looking for smartphone-shaped objects. When it detects one – which it does in less than one second – it shines a light beam onto it.

4. ATmega16 MICROCONTROLLER:

The controller also runs necessary software to analyze the data from the camera to detect a smartphone. To be charged by the light charger, the

smartphone must integrate a solar panel to harvest energy from the light beam of the light charger.

The ATmega16[5] is a low-power CMOS 8-bit microcontroller based on the AVR enhanced RISC architecture. By executing powerful instructions in a single clock cycle, the ATmega16 achieves throughputs approaching 1 MIPS per MHz allowing the system designed to optimize power consumption versus processing speed. The ATmega16 AVR is supported with a full suite of program and system development tools including: C compilers, macro assemblers, program debugger/simulators, in-circuit emulators, and evaluation kits.

5. RELAY:

A relay is an electrically operated switch. Many relays use an electromagnet to mechanically operate a switch, but other operating principles are also used, such as solid-state relays. Relays are used where it is necessary to control a circuit by a separate low-power signal, or where several circuits must be controlled by one signal.

6. BIPOLAR RELAY:

A bipolar relay consists of two semiconductor junctions that serve a broad number of electronic uses from audio amplifiers to digital circuits. In a simple relay the current flows in one direction only, but in a bipolar relay the current flow takes place in both the directions. Which is necessary in our project because we've used a microcontroller which accepts one condition at a given time, and we want to run the microcontroller for two conditions.

7. BLUETOOTH MODULE:

"Bluetooth" technology, first developed in 1994, got its name from a 10th century Danish king named Harald Bluetooth, who was said to unite disparate, warring regional factions -- much like Bluetooth is intended to provide a common communication medium for technologies in different industries (e.g., computers, mobile phones, and automotive devices).[3]

8. PV PANEL:

A PV battery or PV panel usually consists of an array of small PV cells. Various types of semiconductor material can be used to build PV cells. Different materials are of different cost and have different efficiency in converting light into electricity.



V. RESULTS:

Sr. No.	Smart phone	Screen size* (solar panel size) (measured diagonally) Cm	Battery rating (smart phone) mAH/Wh	Charging percentage acquired in 15 minutes	
				With normal charger	With solar panel
1	Lenovo K5 plus	17	2750/10.5	9%	8%
2	Samsung GTS6272	17	1500/5.7	6%	5%
3	Lenovo K4 note	17	3300/12.54	6%	4%

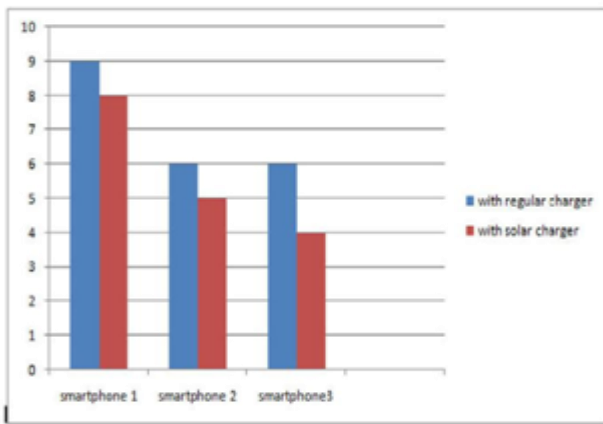

- AutoCharge approach is that it does not work for existing smartphones because it requires that smartphone must integrate a PV panel to work with a light charger.

VIII. CONCLUSION:

A new approach that enables automatic smartphone charging from a user's existing action of putting a smartphone on a desk and automatically charging the smartphone without requiring explicit effort from the user is discussed. To achieve it, mature solar charging technique is used but we use it in indoor spaces. Study of designing a dedicated light charger to generate a light beam to charge a smartphone without a wire and address the practical issues of indoor light charging is in progress.

REFERENCES:

- 1) Yunxin Liu, Zhen Qin, Chunshui Zhao Microsoft Research, Beijing 100080, China : AutoCharge: Automatically Charge Smartphones Using a Light Beam
- 2) Evan Ackerman, spectrum.ieee.org: AutoCharge is Microsoft Research's Take on Wireless Charging with Light
- 3) Wikipedia: Bluetooth Module
- 4) MatLabGUIbuilding: <http://blogs.mathworks.com/videos/category/guio-r-guide/>
- 5) ATmega16 - <http://www.atmel.com/devices/ATMEGA16.aspx>