

Advances in Programmable Logic Controller (PLC) Applications

Dr. Hugh Jack

Grand Valley State University, USA.

Abstract

In this paper mainly three applications are controlled by PLC (Programmable logic controller). which are DC Motor, Stepper Motor, Traffic Light control applications. The hardware components interact with each other and study to how control with the help of PLC. In DC motor application, forward and reversal control of motor using PLC. In application of Stepper motor, control the speed and direction of rotation with the phase angle. In Traffic light. The system operates with traffic lights implemented with LED technology. The proposed system makes use of the transmission media to communicate different traffic light groups with a central regulator in order to exchange information about the lighting elements. From the regulator, the status and operation of the traffic light group can be monitored and changed according to traffic conditions and time. This is reduction of maintenance cost and accurately control the traffic light system.

Indexed keywords: PLC (software and hardware), DC motor, Step motor, LED, Traffic light

Article History: Received: 07 December 2024 | Accepted: 11 March 2025 | Published: 22 March 2025

I. INTRODUCTION

We are using 24 V DC power supply circuit to provide supply for DC Motor. In this operation two loading points are there one is for forward loading point and another one is reverse loading point. Two drivers are required. In this application PLC is used to control the operation of a stepper motor. Ladder Logic Diagram, the PLC program, uses step ladder instructions for implementation of the control algorithm. The motion control algorithm includes the control of stepper motor speed and direction of rotation. The stepper motor is a four phase permanent magnet type. Also the proposed system makes use of the transmission media to communicate different traffic light groups with a central regulator in order to exchange information about the status of the lighting elements. The system provides a reduction in the long term maintenance costs, and can be used to remotely control the operation of traffic light.

II. HEADINGS



2.1 DELTA PLC

In this paper we explained operation of DC motor, Stepper motor and Traffic light controlling system. We use Delta PLC for controlling the application. Here Delta type PLC have a 8 inputs and 6 outputs.

2.1.1 WORKING OF PLC

In that system PLC have as a 24V DC power supply. Here we use SMPS for converting the AC to DC then PLC are connected to the application. The basic PLC schema includes memory, CPU, power supply, input block, output block, communication and expansion connections. CPU modules - The Central Processing Unit (CPU) Module is the brain of the PLC and is used to read inputs, execute the control programs and update the outputs. The CPU consists of an arithmetic logic unit (ALU), timing and control circuitry, accumulator, address stacks, program counter and instruction registers. A PLC works by continuously scanning a program. Memory - The memory includes pre-programmed ROM containing PLC's operating system, driver program, application programs and RAM

2.2 DC-MOTOR

We are using 24 V DC power supply circuit to provide supply for DC Motor. In this operation two loading points are there one is for forward loading point and another one is reverse loading point. Two drivers are required one is for forward direction and another is for reverse direction. As per the principle of DC motor, direction can change by reversing or interchanging the terminal voltage, same as per DC motor principle we can change the direction of DC motor. In this system we control switches or input signals are ON /START (to turn on whole connection), STOP (to turn off the whole connection). FRW signal for turning on the forward direction, REV signal for reverse direction. Basic connection diagram of DC motor is as follows.

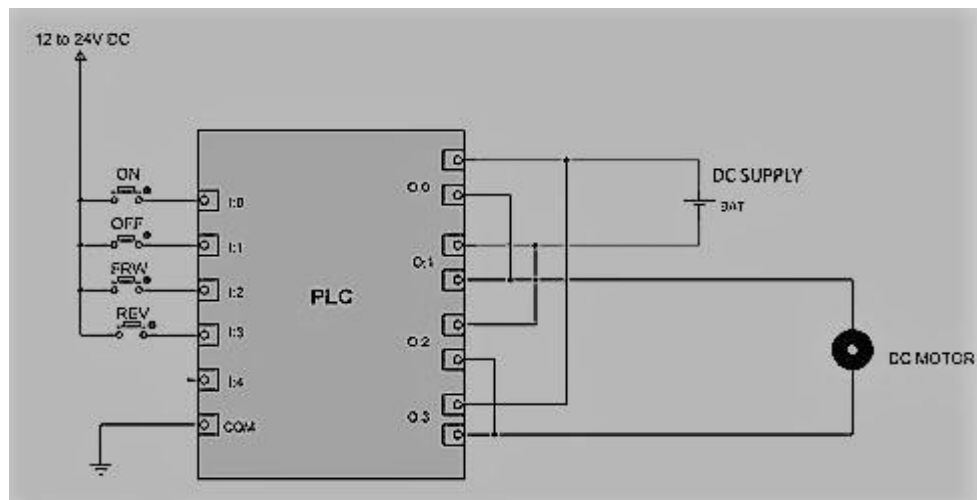

Here is a PLC program to drive motor in forward and reverse direction, along with program explanation and run time test cases.

PLC PROGRAM

List of Inputs and Outputs

I: 1/0 = Forward Start

I: 1/1	= Reverse Start
I: 1/2	= Stop
O: 2/14	= Latched coil 1 for forward
O: 2/0 & O: 2/1	= forward contactor
T4 : 1	= Delay before forward direction
O : 2/15	= Latched coil 2 for reverse
O: 2/2 & O: 2/3	= Reverse contactor
T4: 0	= Delay before reverse direction

LADDER DIAGRAM

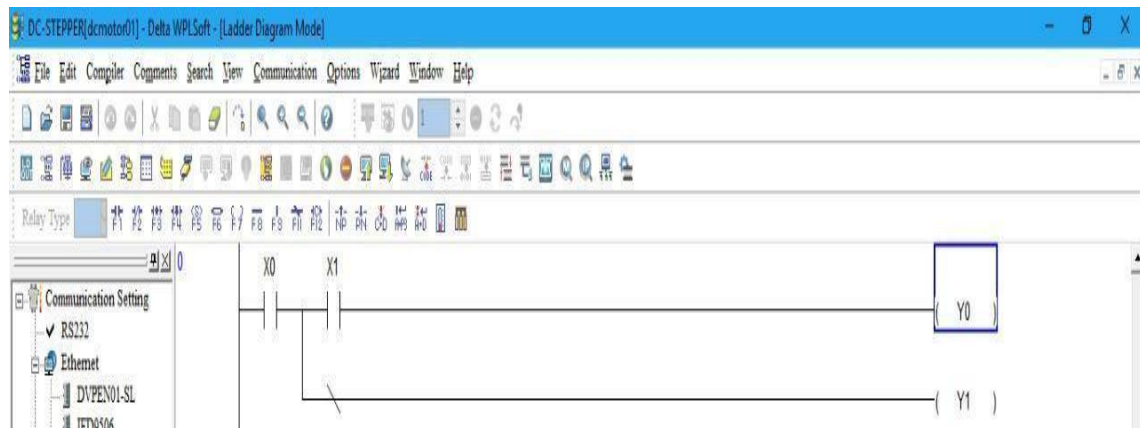

PROGRAM DESCRIPTION

Suppose the motor is running in the Forward direction then, In the Forward direction, O: 2/15 coil2 remains deenergized and reverse action is not activated. TOF is used here so input to T4:0 is true hence timer is not activated. When I: 1/1 is pressed, O: 2/15 is de-energized. When O: 2/15 is de-energized, input to timer T4:1 goes true from false and input to T4:0 goes false from true. Since TOF is used, when input goes true false, T4:0 is activated. X/O of T4:0/DN is given to reverse coil (O: 2/2 and O: 2/3) are not energized until timer counter is completed. Completion of time delay sets done bit to low energizing Reversing coils (O: 2/2 and O: 2/3). Similar operation happens when motor is running in the Reverse direction and Forward direction is given. In this case we use Delta PLC for DC motor operation. There are 8 inputs and 6 outputs from that connections we can change the direction of DC motor. Here we use normal type of DC motor in this application PLC is used t

2.3 STEPPER MOTOR

Operation of a stepper motor. Ladder Logic Diagram, the PLC program, uses step ladder instructions for implementation of the control stepper motor.

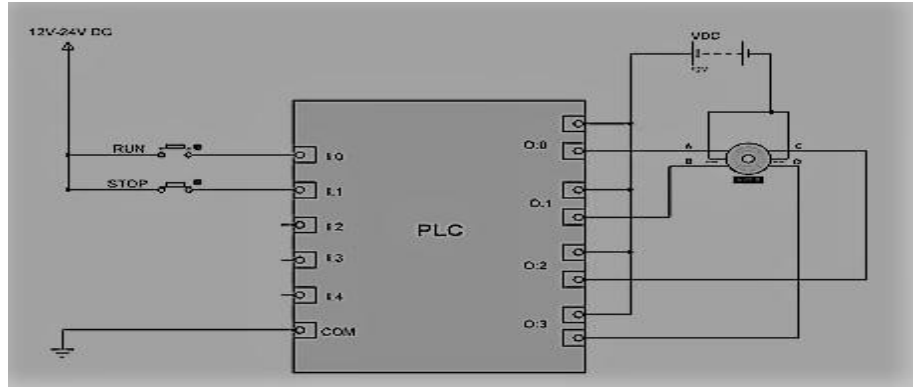

The motion control algorithm includes the control of stepper motor speed and direction of rotation. The stepper motor is a four phase permanent magnet type. The interface board is designed to generate appropriate voltage and current levels for each phase of the stepper motor. The Programmable Logic Controller (PLC) is a relatively new technology that uses a computer to process the information. The control task is incorporated into a graphical program called the Ladder Logic Diagram. Any control task modifications are done by changing the program.

Simple connection diagram of stepper motor using PLC

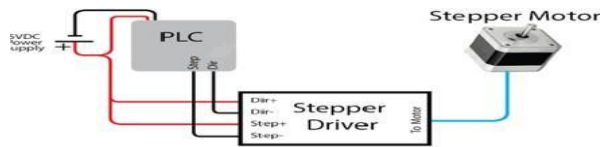

A step motor (or stepper motor as they are commonly referred) is a digital device, in that digital information is processed to accomplish an end result, in this case, controlled motion. It is reasonable to assume that a step motor will faithfully follow digital instructions just as a computer is expected to. This is the distinguishing feature of a step motor.

LOGIC TABLE

STEP	WINDING 1	WINDING 2	WINDING 3	WINDING 4
1.	1	0	0	1
2.	1	1	0	0
3.	0	1	1	0
4.	0	0	1	1

Basic operation of a stepper motor is divided into step wise procedure above fig shows the basic step wise operation of a stepper motor. Here we build four steps as shown in that above fig. there are four windings wdg1, wdg2, wdg3 & wdg4 whenever motor start then sequentially motor create steps and one cycle completed. Driver circuit is also used in that operation. In the Robotic system we can use the stepper motor for getting step wise operation of the system. is implemented in what is known as the Ladder Logic Diagram. It is called that because its shape resembles a ladder. The inputs which are

received from the Input Module are called contacts and the outputs called coils are on the Output Module of the PLC system. The outputs are used to drive various output devices. Each rung of the Diagram contains contacts on the left side and coils on the right side. Then it executes user's program (Ladder Logic Diagram also located in memory) and updates the Output Image Table. As the last step, the system activates or deactivates various output devices that are connected to the Output Module of the PLC.

LADDER DIAGRAM OSS LADDER DIAGRAM OF STEPPER MOTOR

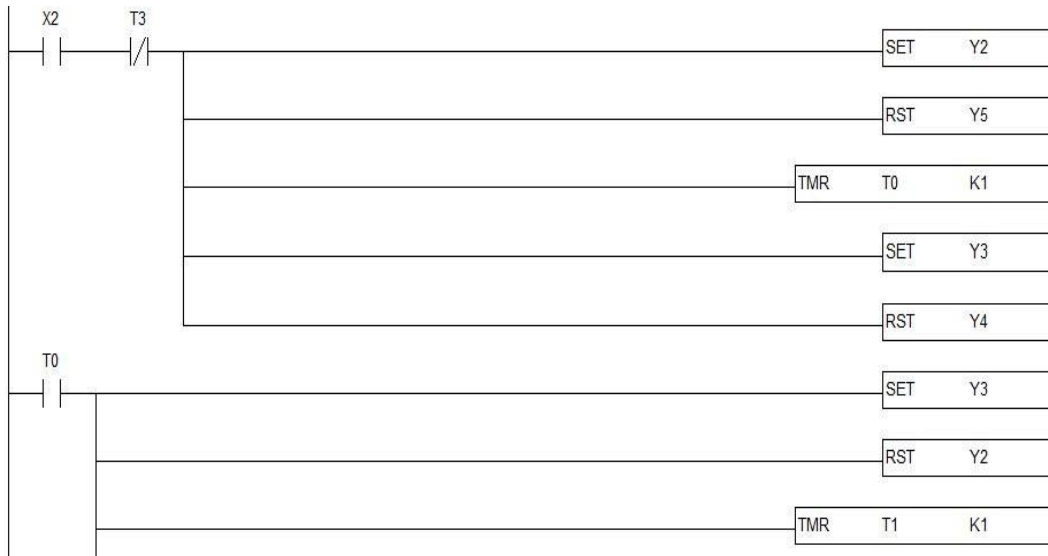

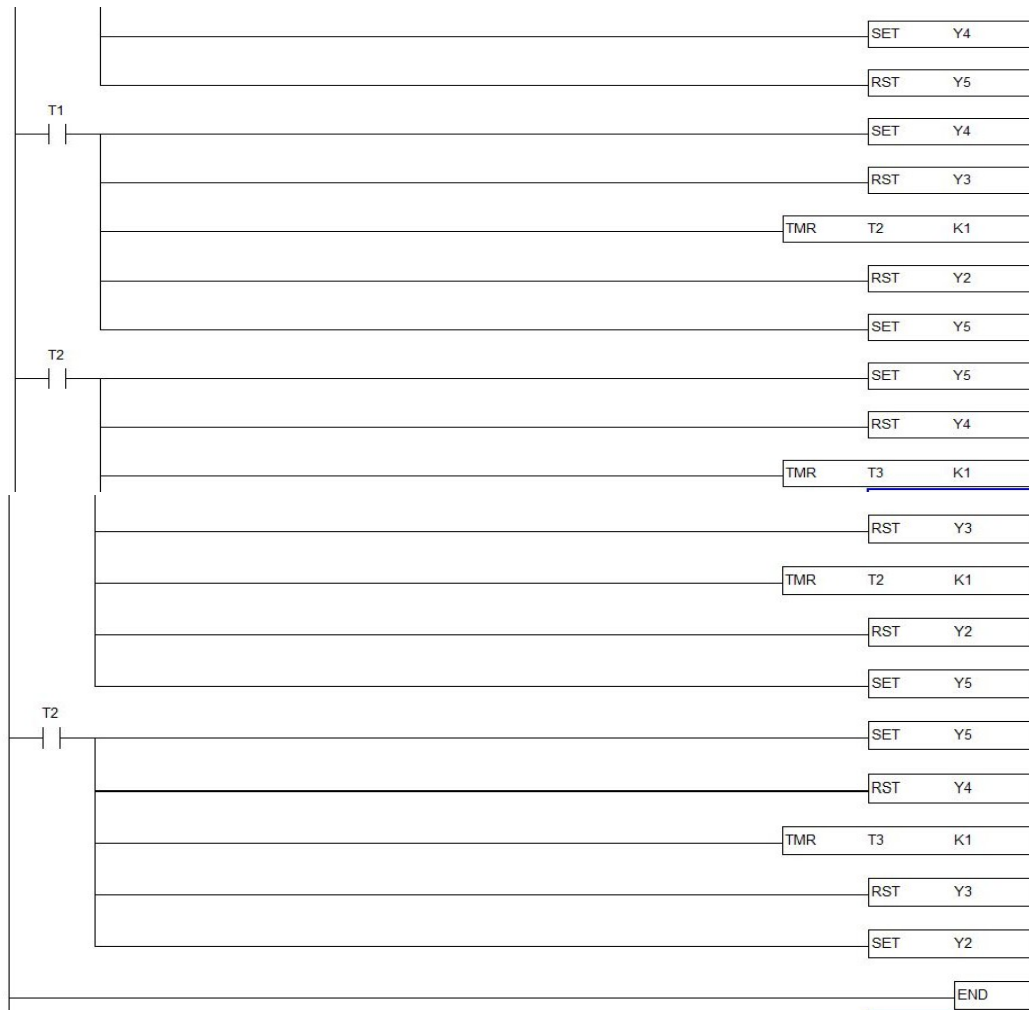

3.3 TRAFFIC LIGHT CONTROLLER

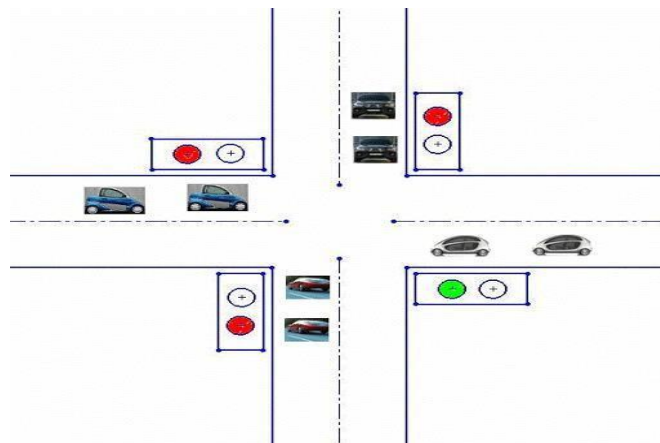

In PLC environment, a program her ever passage is to be given to pedestrians to cross a road. It is also used wherever two paths cross each other thus creating a four-way lane. These systems are also put

in place at points where there are by-lanes attached to the main road Traffic Control Systems are used at a point where there are more than two paths for passage of vehicles or. The main aim of a traffic control system is to control the flow of vehicles through a lane and prevent accidents or road blockage. These systems are also used at points wherever a vehicle needs to be stopped for any purpose. In our country the traffic control system is mostly based on sequential logic. There are three lights red for stop, yellow for get ready and green for go. Each light operates for a given period one after the other. The programming is so done that two lanes won't have the green light at the same time. The traffic control system at a certain places are even controlled manually by traffic personnel but human error calls for automation to prevent undesirable incidents on road. The traffic signals control the vehicle movements. They are connected to electronics system which control the signals. They mainly work on logics which can be classified as

- a. signal phase and cycle length which is dependent on the traffic flow on the desired tracks.
- b. system responds to interrupts or timing based system and open the desired signal as required

3.4 CONCLUSION

We are controlling the motor in forward and reverse direction by using DELTA PLC The stepper motor controller was tested and the results show that its operation is consistent with the theory described in this article controls the speed of the motor. Because one only switch was used, only two speeds are possible The software can be modified to include more than one switch and thus provide the capability of controlling more than two speeds. In order to view the stepping motion of the motor, the speeds used in the experiment were somewhat slow. This method will help reduce congestion on roads and would help in coping with accidents as the heavy vehicles and light vehicles will be in d different lanes. Resultantly, a solution to a much critical problem of traffic congestion and fatal accidents is possible using this system. Thus the proposed system would make our roads a safer p lace to travel. An intelligent traffic light system had successfully been designed and developed. The sensors were interfaced with Lab PLC Module. This interface is synchronized with the whole process of the traffic system. This prototype can easily be implemented in real life situations. Increasing the number of sensors to detect the presence of vehicles can further enhance the design of the traffic light system.

REFERENCES

- I. A zuraCheSoh/Lai Guan Rhung “MATLAB Simulate ion of Fuzzy Traffic Controller for Mu ltilane Isolated Intersection”
- II. www.enggjournals.com/ijcse/doc/IJCSE10-02-04-11.pdf
- III. M. Flynn, P. McMullen, Solis, High-speed flywheel and motor drive operation for energy recovery in a mobile gantry crane, Center for Electro mechanics, University of Texas, VYCON, Inc. 12880 Moore Street, Cerritos, CA 90703, and O. Solis. VYCON, Inc. 12880 Moore Street, Cerritos, CA 90703.
- IV. Nader A. Nayfeh, adaptation of delayed position feedback to the reduction of sway of container cranes, Thesis, Virginia Polytechnic Institute and State University, Blacksburg, Virginia, December 4, 2002.

