

Development and Implementation of Real-Time Railway Traffic Control Systems Utilizing RF Technology

Dr. Priyanka R. Desai, Dr. Kunal A. Chavan

*Department of Electronics and Communication,
Goa Engineering College, Ponda, Goa, India;
Department of Electrical Engineering, Vellore
Institute of Technology, Vellore, Tamil Nadu, India*

ABSTRACT:

With the amplified demand on railway services all over the globe as cheapest medium of transportation, overall railway infrastructure has been developing rapidly in the last two decades, including its communication system. In the past wired communications system were used for signaling and data communication in the railway industry. Radio wave systems become more reliable and cheaper; it becomes feasible to use ad-hoc radio communications as an additional layer of safety, for prevention of crashes between trains in a rail control system. This has led to the invention of new features for railway safety, high speed monitoring of railway conditions. Conventional methods of railroad maintenance and safety assurance are based on separate periodical inspections of track and equipment. These methods have many limitations like problems about signaling system caused by configuration, high construction cost, inefficiency about maintenance work, long downtime etc.[1]

INTRODUCTION:

This paper introduced a low cost, low-power embedded system for railway traffic control and train collision avoidance. We will be using LPC 2138 (ARM7TDMI micro-controller) for low cost, low power, fast and reliable performance [2] as a hardware platform to monitor and control the stations and trains operation and ZigBee as an communication platform of wireless area network, which can receive and transmit also display the station name, train information, warning or situation based alarms and

emergency signals. ZigBee is low-data-rate wireless network technology, which is based on the IEEE 802.15.4 wireless personal area network standard. And the ZigBee's data rate is between 10Kbps and 250kbps. ZigBee can build up to a few tens of thousands of wireless transmission module consisting of wireless data transmission network platform through the network node. Each network node can extend the distance from the standard 75 meters to several hundred meters, and even a few kilometres [3]. To avoid collision, rail routes will be divided into number of segments, and these segments will be electrically insulated from one another [4]. Each train will communicate with nearest station/train [5]. Train will share information like train ID, track ID etc. And receiver will receive this signal and take action (if required). In this system data acquisition and record system also plays important role. Data acquisition and record system can collect, record the data [6]. Station controller will communicate with PC using RS-232 serial communication and display data. This data can be later useful for analysis, decision making purpose etc.

The demands for railway services, train speed and density are consistently increasing in the last two decades. As a result, more strict safety requirements for railway signal control and infrastructure are needed. Accompanying that trend, in recent years, wireless communication techniques have also advanced rapidly. Especially with smart low cost wireless communication techniques like ZigBee going into maturity, thus making it possible to develop a wireless system to monitor and control railway's signaling condition. Also, as radio systems become more reliable and cheaper, it becomes feasible to use ad-hoc radio communications as an extra layer of safety, to prevent crashes between trains in a light rail control system. An effective low cost monitor system will help the normal function of railway systems. This paper gives a description of the development of one such monitoring system. This paper presents existing wireless techniques used in the railway industry for both communications and signaling purposes. In this paper low cost and low power embedded systems for controlling the railway traffic control and collision is been presented. For implementation of this system 32 bit LPC 2138 microcontroller of ARM7 hardware is used. The advantage of using this hardware platform is it can combine and transmit zigbee communication platform for wireless area network which is basically used for transmitting and receiving and display station name and other related information.



LITERATURE REVIEW:

- 1 **Takashi Kunifuji (2002)**, describes the problem with present signalling equipment system. The problems are it takes high cost for construction, it need much work for maintenance and it takes much time for restoring when it has failed. So he introduces a network system, which controls railway signalling equipment and applications utilizing this network. In signal control network all signal control conditions are multiplied on one pair communication cable. And all sort of data for controlling signal equipments are shared over the network. This characteristic brings an advantage for the signaling system in the following point, one is reducing of the construction cost and another one is improving flexibility about extension. Also, the signal control network is accessible from supervision via internet.
- 2 **Simon Segars (2002)**, describes, it is required that hardware system have to be fast, low power, and multifunctional for better communication and information services. To fulfil this requirement, the trend to integrate all the major system functions into a single chip becomes rapidly increased. The key technology in integrating large amount of hardware and software into a single chip is not chip fabrication but CPU core design. It is possible that hardware systems with *SOC's* (System on Chip), which have embedded CPU core, can have lot of flexibility in implementing complex algorithms for information technology fields. The different processors for embedded systems and their architecture are discussed. It also discusses about various metrics used to evaluate the performance of embedded processor.
- 3 **He Hongjiang (2008)**, describes the application of ARM And ZigBee Technology Wireless Networks in Monitoring Mine Safety System. He uses the characteristics of wireless sensor networks and the mature communication technologies of CAN BUS; it implements real-time monitoring and intelligent warning for underground environment and production parameters. This system is equipped with a low power ARM processor chip S3C2410 as the control of the core and ZigBee as a communications platform of wireless
- 4 **Geethanjali M. (2013)**, have stated anti-collision system is designed based on wireless communication. The train tracks in railway network are segmented and given with distinct track numbers which are read by surveillance system. This unique track numbers of shared with neighbour trains using Radio frequency Communication by surveillance system.
- 5 **K. Liu (2008)**, describes a smart low cost wireless communication technique like WIFI, Bluetooth, and ZigBee going into maturity, to develop a wireless system to monitor a railway's signaling or control or infrastructure condition. The whole system consists of one remote controller and many monitor units. The Remote controller is a computer incorporated with a transceiver. The remote controller communicates with the nearest monitor unit and it is through this communication that an operator is able to get data from all monitor units and sends control commands and monitoring or control information to the monitor units. Monitor units are used to collect all kinds of information on track condition and signaling. There are two kinds of monitor units: one is static and each is distributed along the railway, has determined locations and exists all the time in the network. The other is dynamic and the unit is installed on the train locomotive, so that it "joins" the network dynamically and changes their locations continuously. Every unit has its unique identity and has both data acquisition function and data communication function.
- 6 **Huali Chen (2008)**, presents the novel data acquisition and record system based on ARM, GPS and ZigBee technology, which is subsystem of underground oil pipe online monitoring system and can implement real-time data acquisition, real-time data storing and unloading, real-time synchronization, data communication (wire and wireless), data real-time displaying, detecting fault, giving an alarm and so on. The system adopts Used the 32 bits LPC2220 microprocessor of ARM7 as hardware platform, and combined μ C/OS-II realtime embedded operating system, global positioning system with ZigBee of wireless local area network, the data acquisition and record system not only can collect, record, transmit (wire or wireless), display the complex industrial signals and so on, but also can control these procedures.

PROPOSED WORK:

In the proposed signalling system, two railway station controllers are communicating with each other through RF transmission [1]. Depending upon whether the platforms, tracks are empty or occupied, the train traffic signalling is controlled by station controller. Also, if two trains are on the same track, train collisions are also prevented during a signalling system breakdown. Here, each train is implemented with RF module, transmits its

data to other trains/stations [2]. Trains receive data on each other's locations and based on these data an alarm is given if there is the danger of a possible train collision occurring. The driver can then take the appropriate measures to avoid an accident. Also proposed system detects train accidents and that information is transmitted to stations/trains for further actions like disaster management, decision making strategies [5].

This paper describes a recently developed remote monitoring system, based on a combination of embedded computing (ARM7) and wireless communications technology like Zig Bee to monitor and control the health of railway traffic signaling and train collision avoidance.

Station Controller

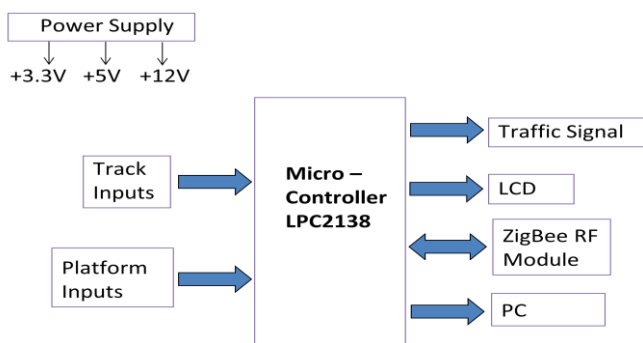

Train Module

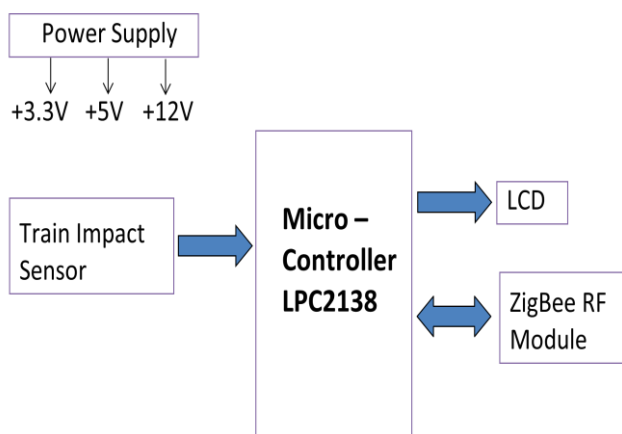

We have decided to use the microcontroller LPC2138 of ARM7 as hardware platform to monitor and control the station and train operations like controlling the traffic signal, communication between train and station. The system will consist of two station controllers (station controller A and station controller B) and two train modules (Train module-1 and Train module-2). Initially station controller will read platform and track input status. When command is received by station controller,

it will check whether the command received from another station controller or from Train module. If command from another station, it will check platform and track status and accordingly send reply. Now if command is received from Train module, station controller will retrieve train route and check whether the down train or up train. Then station controller compare received station number with its own station number. If match is found train is coming from previous station, otherwise received command from train is discarded. Then platform status is checked, if empty green signal is given to train. Then it checks track status to depart the train to the next station. If track is free, request will be send to next station to check the status of their platform. When next station sends positive reply, track relay output is turn on with green signal indication. Similarly when command is received by Train module, it will check received command from station or from train. Here train will broadcast route information, track no. and train ID. If command received from station, it will update its route information. Now if command is received from another train, then train will compare received track no. with its own track number. If match is found there is possibility of collision on the same track, so buzzer is turned on and an emergency message is send on LCD. Then driver will take actions to avoid it.

CONCLUSION:

1. **It will provide low cost, Fast and reliable solution to avoid train collision.**

Recently wireless communication systems have emerged as alternatives to replace wired system in railway industry. We will use LPC2138 processor of ARM7 as a hardware platform for controlling the railway signalling operation and/or train operations and for communication platform will use ZigBee.

2. **It will help in reducing collision of trains**

The train tracks in railway networks are segmented and given with distinct track numbers which are read by system inside the locomotive. The track number will be shared with neighbour train using Radio Frequency Communication by the System. The system then compares its track number with neighbour train track numbers, on locating same track numbers, steps are taken by the surveillance system to caution the concerned motorman in order to stop the train and avoid mishaps.

REFERENCES:

- 1) Takashi Kunifuji, “*Safety Requirements about Railway Signalling System Utilizing Network and its Implementation*”. IEEE Transaction on Data Communications, Maintenance engineering, Volume: 2, Page:579, 2002
- 2) Simon Segars, “*Embedded Control Problems, Thumb, and ARM7TDMI*”. IEEE Transaction on Micro, Volume 15, Issue: 5, Page: 23, 06 August 2002
- 3) He Hongjiang, “*The Application of ARM and ZigBee Technology Wireless networks in Monitoring Mine Safety System*”. IEEE Transaction on Computing Communications, Control and Management, Volume: 2, Page: 430, August 2008
- 4) Geethanjali M., “*RF Based Train Collision Avoidance System*”. Page: 1 and 2 Published in 13-15 December 2013.
- 5) K. Liu*, “*Smart Wireless Railway Monitoring System*”, Transaction on railway communication, intelligent sensors, Page: 1, 18-20 June 2008
- 6) Huali Chen, “*Design of Data Acquisition and Record System Based on ZigBee and GPS*”. IEEE Transaction on Computation Intelligence, Volume: 1, Page: 682, 19-20 Dec, 2008.