

# Enhancing Engineering Education through Innovative Laboratory Design

Dr. Gábor Stépán

Budapest University of Technology and Economics (BME), Hungary.

## Abstract

This paper presents the use of a new experimental setup for power electronics and electrical drive experiments in teaching Electrical and Electronics Engineering bachelor students. The setup is developed in the context of educational innovation and is configured to closely resemble industrial appliances that are used in power electronic converters for DC-DC, DC-AC and AC-DC conversion. The hardware allows students to perform laboratory experiments with voltage levels below 60 volts and under 200 Watts, to comply with DC grid LVDC standards. Applications range from battery charging, solar panel maximum power point tracker, DC-DC conversion to single phase and three phase AC applications such as motor drives, grid-tied connected inverters and wireless power transfer. Moreover, the applications can be tailored to apply in other disciplines, such as Mechanical Engineering and Mechatronics. A set of experimental assignments guides students from theoretical principles, via idealized simulations to measurements. Finally, students perform laboratory experiments in which they are assessed on their verification of the theoretical and simulation results together with measurement outcomes. Since the setup is constructed in the same way as an industrial application, typical measurement results due to parasitic components, are visible to the students. Compared to commercial educational training hardware, the industrial construction is more close to reality and better prepares students to understand the working of power electronics and electrical drives. The combination of the industrial design approach and multidisciplinary flexibility of hardware, laboratory experiments provide students a realistic and enhanced learning experience.

**Indexed keywords:** Computer Engineering, Advanced Computing, Technology, Open Access

Article History: Received: 21 December 2024 | Accepted: 24 March 2025 | Published: 08 April 2025

## 1. INTRODUCTION

Learning by doing is a method where students can learn technical skills using laboratory assignments. Especially in electrical engineering, laboratory skills are essential for understanding in depth the working and behavior of typical applications and components. Simulation and Animation is one of the methods for students to gain some knowledge on the working on circuits and components [5][6][7][8].



Experimental setups and laboratory assignments are common practice in the study of electrical engineers, however little is known on the acceptance and achievements by the students. In this study we present an improved version of a laboratory setup[9] that can be applied to a variety of applications and we conducted a survey on the use of the experiments and the laboratory set up. Based on the outcomes of the survey, the assignments and the laboratory set up can be improved.

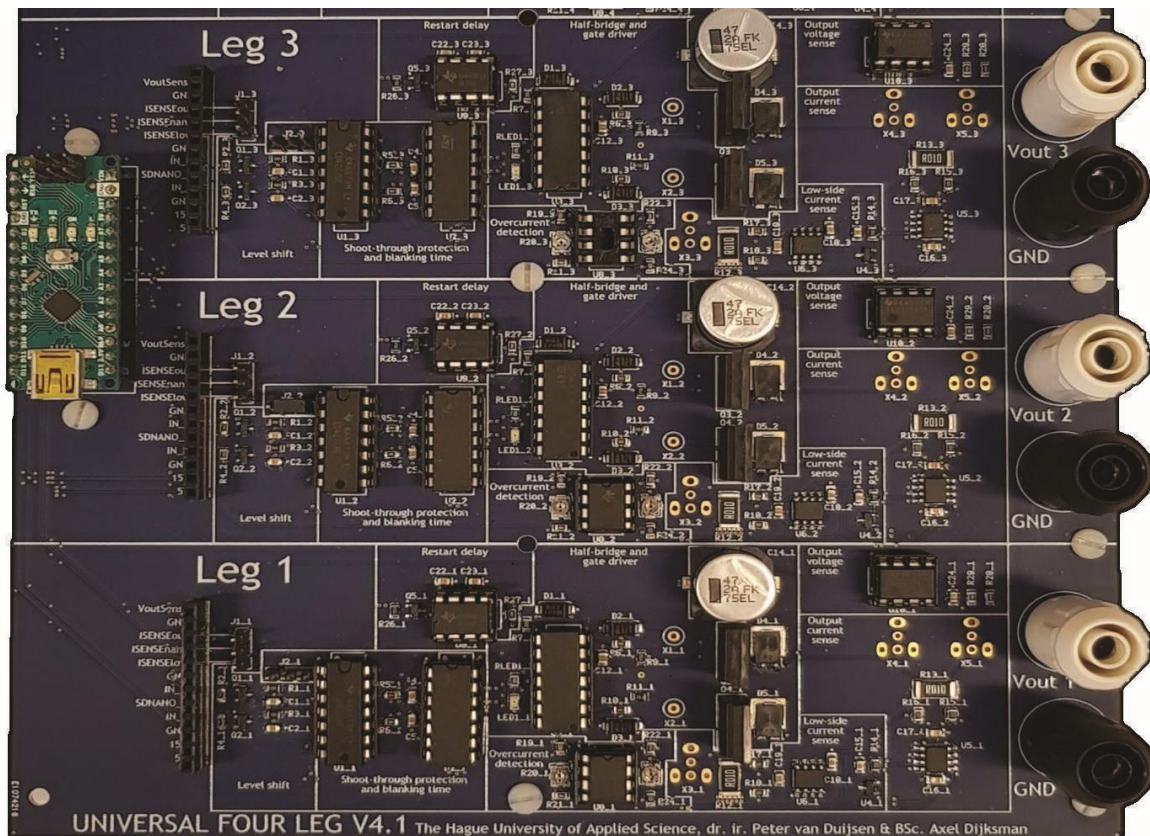

Fig. 1. Three Legs of the fully assembled Universal Four Leg with an Arduino Nano.

The Laboratory assignment is built around the theory from the lectures[1] and has to be practiced using simulation[2] and measurements[9]. First the students have to prove their knowledge with simulation assignments. After approval, they have to examine the working of the Universal Four Leg board and do measurements on the board, explaining the functions of all components. In Fig. 1. we see the fully assembled Universal Four Leg also known as the U4L. After a short explanation of the working and components of the experimental set up, an example is given of a student assignment. Secondly we describe the methodology we used to conduct the survey and the evaluation of the results from the survey.

## 2. EXPERIMENTAL SETUP

The U4L can be used in various experiments. Mainly the applications are diverse on one hand, but on the other hand they mostly converge to the same type of hardware topology. In many applications, ranging from switch mode power supplies with

synchronous rectification, half bridge, single phase full bridge to three phase full bridge the totem-pole connection of two Mosfets like in *Fig. 2* below dominates. Therefore the U4L is constructed from four independent half bridges that can be configured to create the various topologies.

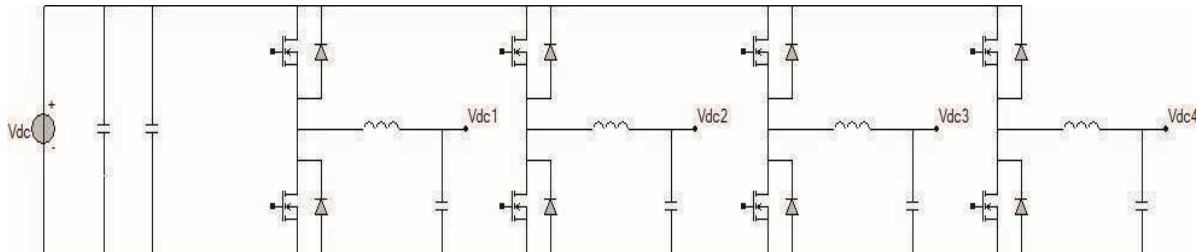

*Fig. 2.* The topology of the Universal Four Leg

The control and protection of each half bridge as well as the measurement circuits are equal for all four half bridges. Therefore it is possible to use only a single leg to build a switched mode power supply but by combining three legs, one can build a three phase inverter.

## **ELECTRIC CIRCUIT**

Each leg on the U4L is configured to work independent of the other legs. Therefore the description of the used circuit is limited to a single leg. It starts with the level shifting of the input signals to be compatible with 3.3 volt and 5 volt systems. It is followed by a shoot-through protection and logic blocks to prevent over-current. The over-current is measured on the low side Mosfet and on the outgoing current. Using a jumper, the user can switch between the two measured signals. All current measurements and output voltage measurements are buffered using a high bandwidth Op-amp. The current signals are filtered to remove the spikes from Mosfet switching and the output voltage is averaged.

## **APPLICATIONS**

The main applications are the DC grid related experiments and three phase motor control experiments. A typical experimental set up for a DC grid using a solar module and Li-Ion battery is elaborated in this section.

### ***DC Grid***

Switched mode power supplies are the emerging applications that are always required to control the amount of DC power that flows between source and load. The applications are numerous. Using a single leg, the Buck, Boost and Buck-boost converter can be configured. The on-time of the Mosfet switches of the converter are controllable and the amount of voltage and current at the output of the converter are measurable and can be used in the control of the converter. The control of the

converter itself is done external to the U4L and can be either an analog or digital control.

### **Battery charging and discharging**

Battery charging mostly implies constant current and constant voltage supply to charge the battery. The constant current supply is achieved by controlling the output voltage of the converter such, that the output current remains constant. As soon as the voltage level of the battery rises above a certain level, the control of the converter is changed to a constant output voltage. The charge current can be measured and as soon as the battery is filled, that charge current will drop below a certain level indicating that the battery is fully charged.

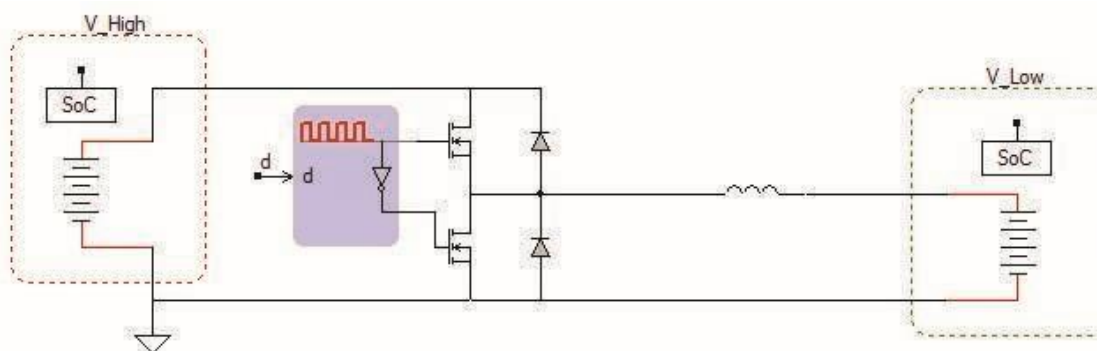

Fig. 3. Battery charging and discharging topology.

The control of the charge current is simply done by setting the on time of the high side Mosfet such that the outgoing current just reaches the maximum current. Discharging the battery is also possible by simply controlling the low side Mosfet instead of the high side Mosfet. Again the maximum current is controlled, but now with the on time of the low side Mosfet.

In this way a charging and discharging of a battery is done using the same topology and only by controlling the on time of the high or low side Mosfet, the power flow can be controlled as shown in Fig.3.

### **Solar MPP**

For solar applications we basically control the voltage over the solar panel to the maximum power point value {MPP}. Using a boost converter topology where the output voltage of the boost converter is constant, the value of the input voltage is controlled. The amount of current flowing out of the solar panel is simply defined by the voltage-current characteristic for the solar panel for the given solar insulation.

### **Bidirectional power control**

Applying the bidirectional Buck-Boost converter, the power flow in a DC grid can be controlled. Therefore a single leg can serve multiple purposes in a DC grid, such as voltage and current control, including maximum current protection.

### **Analog and Digital control**

With some external components, a breadboard, solar panel and rechargeable batteries, students can build various experiments. The U4L preliminary fulfills the role of a basic circuit that does the power processing. Using external inductors and capacitors filters can be built for connecting auxiliary loads and supplies like a solar panel or a rechargeable Li-Ion battery. The control of the U4L can be performed in two ways. A digital control or an analog control. Both have their advantages and disadvantages such as easy access for the analog control and flexibility for the digital control.

In *Fig. 4* the set-up of a MPP controller for a solar module is shown. The solar panel is connected via an inductor and capacitor to the first leg and digital multimeter is used to measure the average current from the solar module to the U4L.

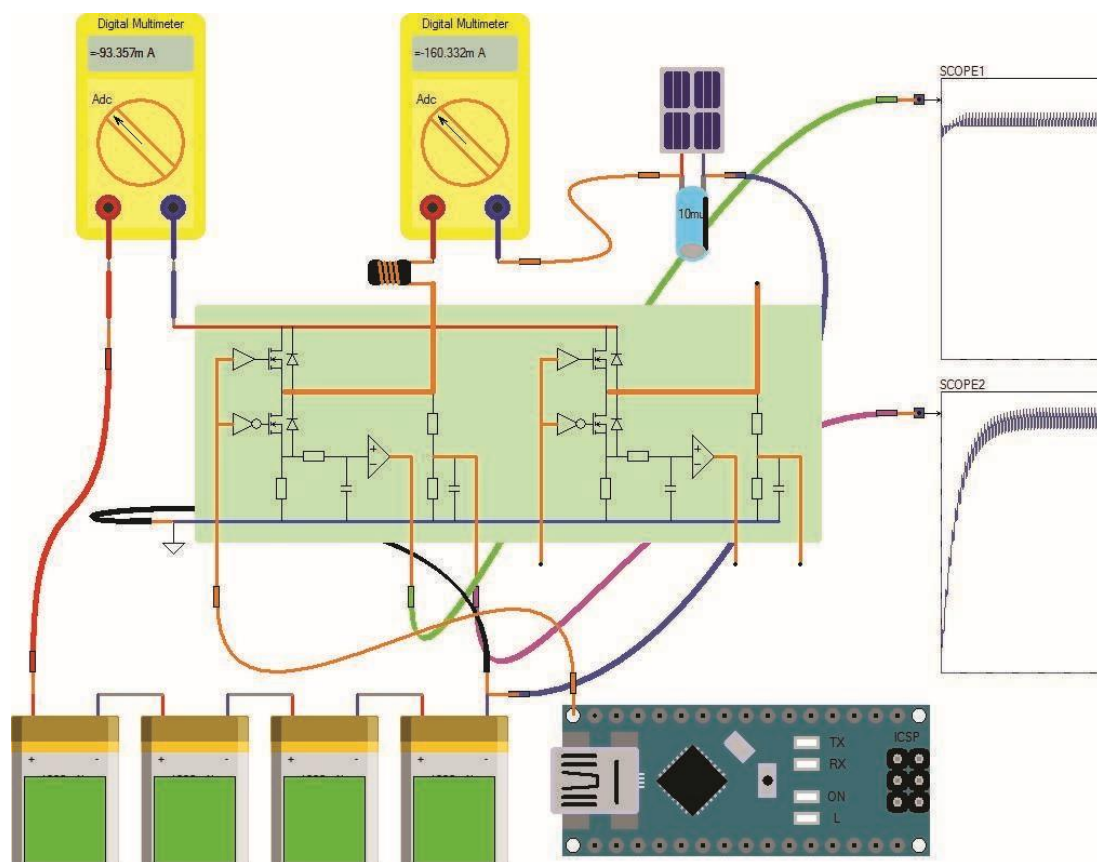

*Fig. 4.* The U4L with Arduino in a MPP controller for a solar module configuration.

Four Li-Ion cells are connected in series to make a DC voltage of 15 volt. The current flowing in and out of the battery is measured by a digital multimeter, measuring the average current.

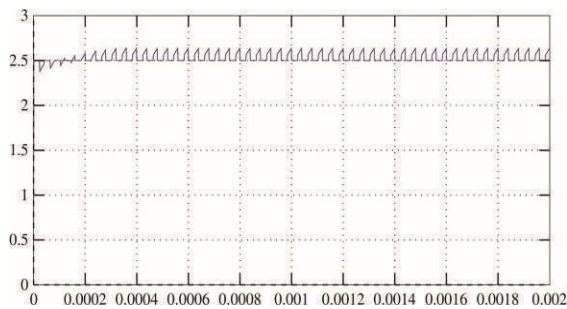

Fig. 5. Scope 1.

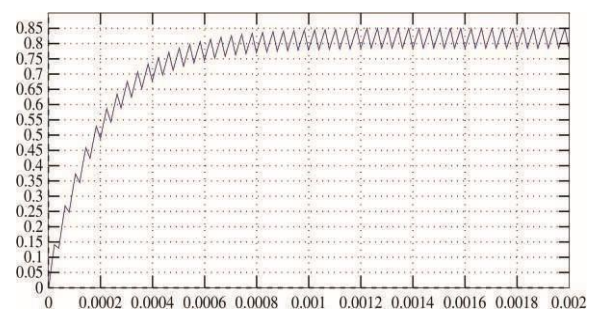

Fig. 6. Scope 2.

Fig. 5. shows the output current as seen Fig. 6. shows the output voltage as by the low side current shunt. Its signal is measured and buffered using a resistive centered around 2.5 volt, being the zero divider. offset.

The control is done using an Arduino Nano [3] microcontroller which generates a Pulse Width Modulated signal with constant frequency and duty cycle. This PWM signal is input for the first leg of the U4L. The output is coupled to the solar module via a series inductance and a small parallel capacitor. In this way a synchronous boost converter is created between the solar module and the DC link, being the four Li-Ion cells in series. The current measurement inside the U4L and the buffered output voltage are displayed in Fig.5 and Fig.6.

The purpose of the assignment for the student is to regulate the U4L in such a way to optimize the energy harvesting from the solar module. By regulating the voltage across the solar module, the maximum power point can be achieved. Students have to find the optimum duty cycle for this. The figure above Fig.4 shows the simulation of this set up. The digital multimeters show the average current of around 160mA for the solar module and 100mA for the DC link current. During the simulation the State of Charge [SoC] of the batteries is displayed in the batteries and running the simulation for a longer time, the students can predict how long it takes to charge the batteries. Increasing the solar intensity in the solar module, default set to 200mW/m<sup>2</sup>, shows that the student has to adapt the duty cycle to stay at the maximum power point of the solar module.

Since reprogramming the microcontroller involves time and knowledge of the students, the second assignment makes use of an analog controller, see Fig. 7 below.

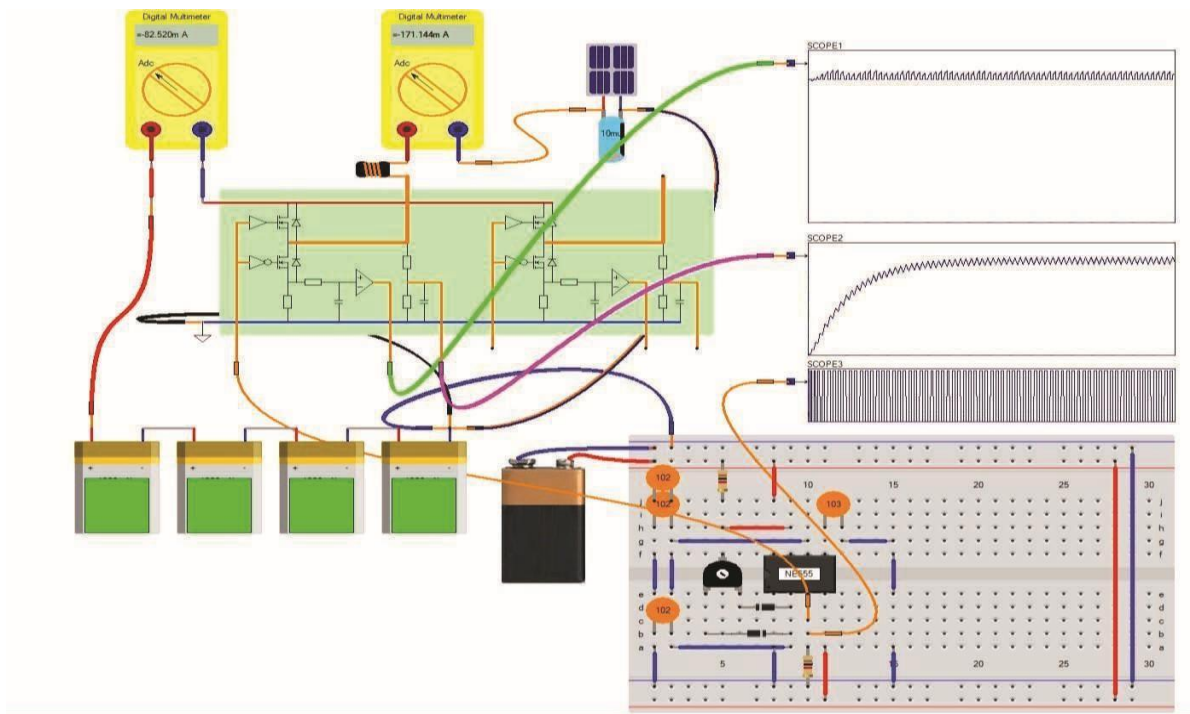

Fig. 7. Combining the U4L with analog circuits constructed on a breadboard.

Here the analog control has to be constructed on a breadboard using various electronic components. The aim is to create a square wave signal with fixed frequency that can be varied in duty cycle. Using a simple NE555 and a variable resistor. The output of this analog control can directly be coupled to the input of the U4L and the power supply for the breadboard comes from a 9volt battery.

### 3. LABORATORY ASSIGNMENTS

The Power Electronic class [1] introduces the theory of DC to AC inverters. For the laboratory assignments the students will use their knowledge gained during the lectures. The knowledge both mathematical and circuit topology give a good base for the students to start with the first simulation assignments. The simulations assignments are done with the Caspoc Simulation Software [2]. Students can open the simulation models corresponding with each assignment. Starting with a pre-configured configuration of all the components needed to build a DC to AC inverter, see Fig.8. After getting familiar with the simulation software Caspoc the student get more challenging assignments. Explaining measurement outputs and explaining circuit behaviour when changing circuit parameters. The nine simulation assignments will be documented with answers to the questions, including calculations and screenshots of the simulation results. All simulations together give a full understanding of the working principal of the U4L.

After completing all the simulation assignments the students may continue assemble the U4L PCB, a snippet of the PCB is shown in Fig. 9. The soldering process of the U4L will be split up in function segments. Every segment has its own assignments with

corresponding questions and measurements. For a higher success rate there is a logic build up from soldering the power supply until the Mosfet power stage. At every segment measurement the current will be limited to prevent big short circuit currents, this to make it safe in use. The students also get familiar with soldering THT and SMD.

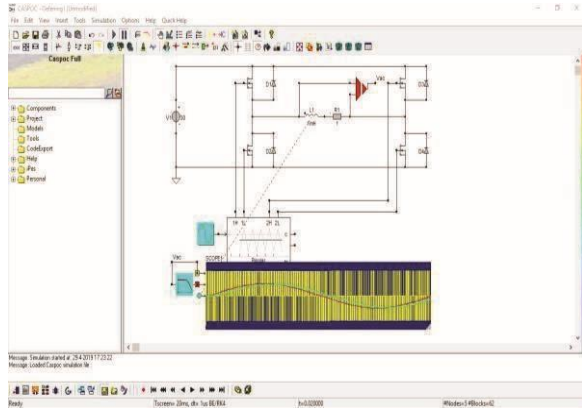

*Fig. 8.* Caspoc Simulation Inverter Model. There are nine simulation assignments witch contain the following subjects:

1. DC to AC inverter model
2. Change Parameters
3. Measurements and Calculations
4. Blanking Time
5. Bipolar Mosfet & IGBT Currents
6. Unipolar Mosfet & IGBT Currents
7. Inverter Current Control
8. Charge Pump Gate Driver
9. Inverter Output Voltage

#### **4. METHODOLOGY**

In order to understand the perception and experience of the hardware in a laboratory training, the presented experimental setup was implemented in the third year elective Power Electronics. During the laboratory training, students have fully access to the hardware and have to complete assignments spread over four sessions. The course is mandatory to attend. A questionnaire with both closed and open-ended questions was designed to seek feedback on student's experience. It consists of:

- Five statements for evaluating student experience of the laboratory assignments
- Four statements evaluating student experience of the hardware
- Four open-ended questions that collected feedback on the laboratory experience and the use of the hardware

Responses to the statements are measured using a 5-point Likert scale, ranging from "1" as strongly disagree to "5" as strongly agree. Both statements and open-ended

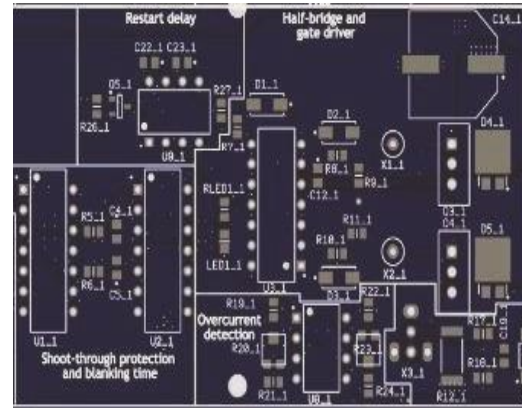

*Fig. 9.* A segment of the U4L PCB. There are seven build assignments witch contain the following subjects:

1. The Power Supply
2. Shoot Through and Blanking Time
3. Mosfet and Gate Driver
4. Measurements Output Voltage and Current Sensing Low-Side
5. Current Sensing High-Side
6. Current Amplifier Low/High-Side
7. Shut-Down, Restart Delay, Overcurrent Detection

questions were presented in Dutch. Out of the 39 students, 22 responded to the questionnaire after the seven week laboratory training was finished.

## 5. EVALUATION

---

Before the U4L was used in the laboratory, it was reviewed by five students that have worked on further development and improvement of the hardware as part of their research or project. Outcomes show that students easily applied existing knowledge in the use of U4L and particularly liked the design and the variety of possibilities. They acknowledged that they were familiar with the internal components, however, students did not particularly gain new knowledge and skills during their use of the U4L. Also valuable feedback for improvement was given on the performance of the microcontroller. The overall experience was rated a 7.4 (on a scale from one to ten).

During the laboratory training, the U4L was incorporated in a setup related to a series of laboratory assignments. Student's comments on the assignments were neutral to positive when it comes to their interest and understanding in power electronics and student's development of knowledge and skills (*Table 1*). Students point out that they are able to see functions of the hardware when performing the measurements. Hence, theory was visible in practice and better understood. Moreover, the assignments provided a realistic example of power electronics application in real life. In contrast, students raised also some criticism on the laboratory assignments. This is further clarified by the answers on the open-ended questions. Students report that they have spent more time than desired on soldering smd components. While soldering smd is an assumed prerequisite, it turned out that students were insufficiently capable of soldering the smd components. This resulted in a delay in the execution of the assignments. Overall, all students suggested to pre-assemble the smd components.

Feedback on the U4L was neutral to positive. Students perceived the hardware as interesting. This is in line with student's feedback on the use of the U4L, which was reported as stimulating (*Table 1*). Moreover, students report that they identified the link between theory and practice while working with the hardware. Furthermore, the U4L resembles a realistic representation of practice. The main criticism on the technical aspects concerned the lack of test points.

In the upcoming power electronics labs a number of control boards and load boards will be provided, so students can perform measurements on various applications. E.g. electrical loads are varying in power level, both single phase and three-phase. Predesigned analog controllers such as P, PI and PID controllers are preparable as control boards,. Students should also be provided with U4L boards, containing preassembled smd components and empty logic IC's. This will give students more time left for doing more measurements related to the power electronics experiments.

*Table 1. Survey results evaluation of the laboratory training (n = 22)*

Survey items	Scores (count)					Median
	1	2. Disagree	3	4	5	
<i>The laboratory assignments...</i>						
make me enthusiastic about power electronics	1	7	9	4	1	4
contribute to my knowledge and skills	0	5	6	11	0	3.5
allow me to gain better understanding of power electronics	2	6	2	11	1	4
helped me in being confident operating a development board	5	8	1	6	2	2
were of satisfying quality	8	8	5	1	0	2
<i>The use of the Universal Four Leg was...</i>						
easy	2	4	10	5	1	3
good to understand	3	2	9	6	2	3
stimulating	1	0	7	13	1	4
satisfying	2	6	10	4	0	3
	<b>Mean</b>					
To what extent do you think the U4L approaches a realistic situation [1 = not at all; 5 = to a great extent]	3.14					

*“When you perform the measurements, it is much better to understand how the hardware works. It gave me a better understanding of the hardware and the theory was easier to understand.”*

*“All functions and features that were given in the lecture were reflected on the printed circuit board. The U4L looked nice and was well designed, but the majority of students lacked prior knowledge regarding soldering of small smd components.”*

## 6. CONCLUSIONS

This paper presents the use of a new experimental setup for power electronics and electrical drive experiments. The purpose of this study was to explore students perceptions of their user experience with the Universal Four Leg and to present a way of how to implement a setup in a power electronic laboratory training. The U4L is configured to closely resemble industrial appliances that are used in power electronic converters for DC-DC, DC-AC and AC-DC conversion that allows students to learn on an industrial construction that is more close to reality, giving better insight in the working of the appliances via experiments. A set of experiments have been developed that will guide students from theoretical principles, via idealized simulations to measurements. At the end of the laboratory training the student should have learnt the

basics of power electronics and are able to simulate, design and measure power electronic systems. And how to use the U4L as a tool in future projects.

Learning by doing is a method where students can learn technical skills using laboratory assignments. The authors expected that the combination of the laboratory assignments and the U4L would clarify the link between theory and practice. Next it was expected that it would increase students interest in power electronics. Feedback on the experience of the laboratory assignments show that students identify the relation between theory and practical application and that this contributed to a better understanding of power electronics. Furthermore, they report that the use of the U4L was stimulating and that they perceive the set-up as realistic. This is in line with the purpose of the authors, since the setup is constructed in the same way as an industrial application it offers students an experience more close to reality. Therefore, it is expected that the level of motivation and satisfaction increases [4]. According to experience-based learning approach, experimental learning requires both thinking and doing which stimulates reflection on the experience. This evokes openness towards new experiences and consequently continuous learning [10]. Moreover, it prepares students to better understand the working of power electronics and electrical drives as typical measurements results are visible, providing students with complete education.

Comments on the current setup also provided suggestions for a change in approach and laboratory setup. Main comments from students were about the complexity of soldering smd components. This resulted in a reduced time for further measurements on the Universal Four Leg. In a next phase, more attention on student's prior knowledge and skills should be taken in account. The experimental setup and equipment is currently being used at the Hague University of Applied Science

## REFERENCES

- [1] van Duijsen P.J. , Lecture/Laboratory: Vermogenselectronica I&II, 2016.
- [2] Caspoc [online], available: <http://www.caspoc.com>, 2019.
- [3] Arduino [online], available: <https://www.arduino.cc>, 2019
- [4] Gol, O., Nafalski, A., and McDermott, K. (2001). The role of industry-inspired projects in engineering education, 31st Annual Frontiers in Education Conference. Impact on Engineering and Science Education. Conference Proceedings (Cat. No. 01CH37193), Vol. 2, pp. F3E-1, IEEE.
- [5] Bauer P., Leuchter J., Steklý V, Simulation and animation of power electronics in modern education, AEE'05 Proceedings of the 4th WSEAS international

- conference on Applications of electrical engineering, Prague, March 2015, Pages 48-52
- [6] Drofenik U. , Kolar J.W., van Duijsen P.J., Bauer P., New web-based interactive e-learning in power electronics and electrical machines, Conference Record of the 2001 IEEE Industry Applications Conference. 36th IAS Annual Meeting (Cat. No.01CH37248)
- [7] Bauer P., van Duijsen P.J., Challenges and Advances in Simulation, IEEE 36th Power Electronics Specialists Conference, 2005
- [8] Bauer P., Kolar J.W., Teaching Power Electronics in the 21st Century, EPE Journal European Power Electronics and Drives, Volume 13, 2003 - Issue 4
- [9] Woudstra J.B., van Duijsen P.J., van Willigenburg P., Witte P.M., DC Educational Development, Improving understanding of DC to DC / DC to AC conversion, SEFI 2018
- [10] Andresen, L., Boud, D., & Cohen, R. (2000). Experience-based learning. In Foley G. (ed.) *Understanding adult education and training*, 2nd edition, pp. 225-239.